

MODEL 230.476 with ENGINE 275.951

MODEL 230.477 with ENGINE 275.954

MODEL 230.479 with ENGINE 275.981

- 1 Bolts
- 6 Screw
- 7 Screw
- 9 Bracket
- 10 Bolts
- 30 Power steering pump
- 30h Gasket
- 30i Power steering pressure line
- 41 Belt pulley
- 58 Hydraulic lines
- 59 ABC pressure lines
- 59a Banjo bolt
- Y86/1 ABC suction restrictor valve

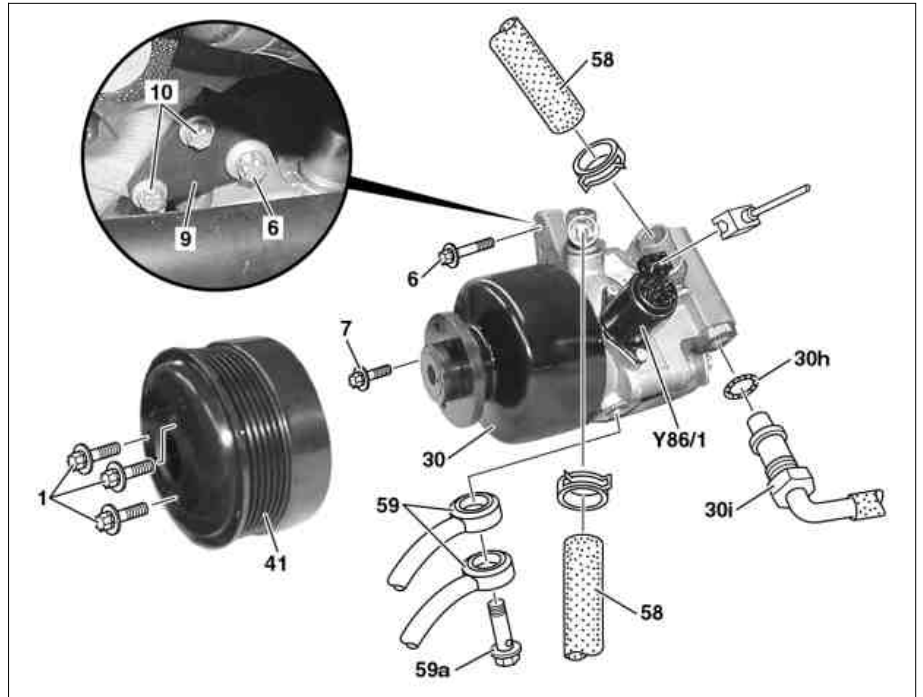

P46.30-2139-06

- 19 Coolant line

Y86/1 ABC suction restrictor valve

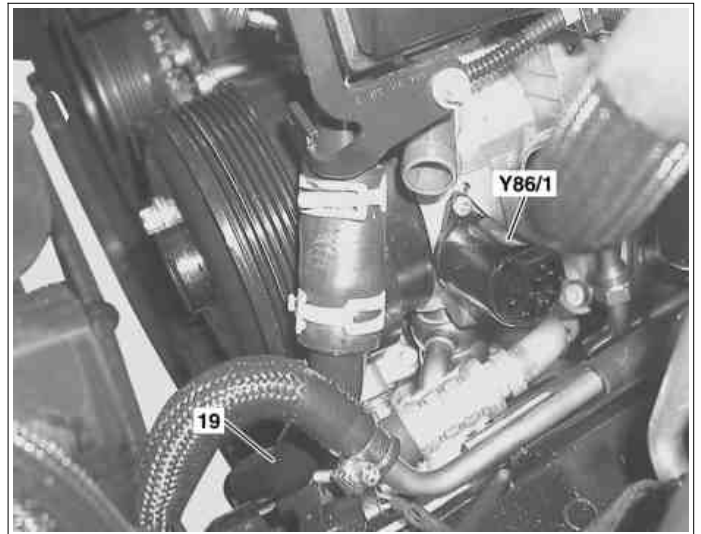

P46.30-2140-11

- 2 Clamps
- 3 Hydraulic line bracket

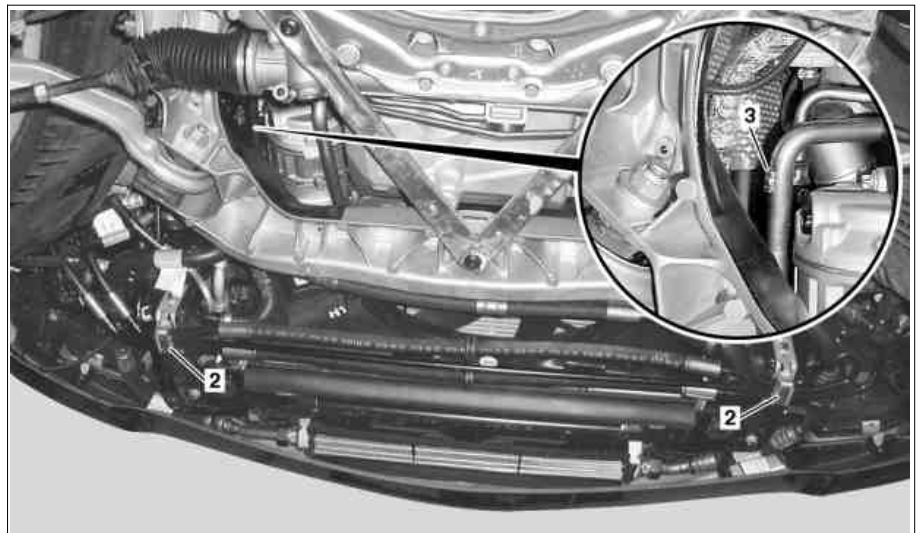

P46.30-2141-05

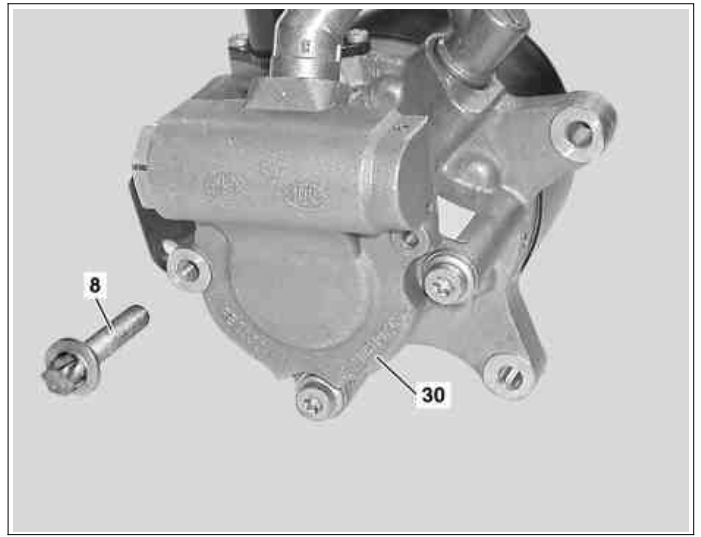

P46.30-2142-11

☒ ☒	Remove/install		
⚠ Danger!	Risk of injury to skin or eyes caused by hydraulic fluid spraying out under high pressure. Risk of poisoning caused by swallowing hydraulic fluid	Depressurize the hydraulic system completely before starting any work on the system. Wear protective clothing and safety glasses.	AS00.00-Z-0013-01A
1	Remove engine trim panel	Model 230.476/ 477 Model 230.479	AR01.10-P-2405LA AR01.10-P-2405IM
2	Detach air intake hoses upstream of air filter		
3	Suction off hydraulic fluid from power steering and ABC system from the expansion reservoirs i Notes on Active Body Control suspension	☑ Hand pump	*210589007100 AH32.50-P-0001-01N
4	Remove left air filter housing		AR09.10-P-1150LA
5	Disconnect plug from ABC suction restrictor valve (Y86/1)		
6	Disconnect hydraulic lines (58) to power steering pump (30)		
7	Remove expansion reservoirs for power steering and ABC system		
8	Remove fan shroud		AR20.40-P-6800AC
9 ☞ WF	Attach guard plate for radiator / condenser Guard plate for radiator / condenser		WF58.50-P-0110-01A
10	Remove banjo bolt (59a) and detach ABC pressure lines (59)	i Installation: Install new sealing rings. Nm	*BA46.30-P-1009-01S
11	Loosen bolts (1) of belt pulley (41)		
12	Remove poly-V belt	Model 230.477 Model 230 except 230.477	AR13.22-P-1202L AR20.00-P-1142HM
13	Drain coolant from low temperature circuit		
14	Remove coolant line (19) to circulation pump of low temperature circuit		
15	Disconnect power steering pressure line (30i) from power steering pump (30)	i Installation: Replace sealing ring. Nm	*BA46.30-P-1009-01S
16	Loosen clamps (2) of ABC hydraulic line on radiator traverse		
17	Detach hydraulic line bracket (3)		
18	Remove belt pulley (41)	Nm	*BA46.30-P-1006-01S
19	Remove bolt (6) and bolts (10) and detach bracket (9)	Nm Nm	*BA46.30-P-1001-01S *BA46.30-P-1002-01S
20	Remove screw (7)	Nm	*BA46.30-P-1002-01S
21	Remove bolt (8) and remove power steering pump (30) forwards	i Installation: Position the bolt (8) first and then bolt (6), bolt (7) and bolts (10). Tighten bolt (8), then bolt (6), bolt (7) and bolts (10). Nm	*BA46.30-P-1002-01S
22	Install in the reverse order		
23	Fill and bleed active body control (ABC)		AR32.50-P-0021N

Nm Power steering pump

Number	Designation		Model 230 with engine 275
BA46.30-P-1001-01S	Bolt/nut tandem pump/power steering pump to timing case cover	Nm	20
BA46.30-P-1002-01S	Self-tapping screw tandem pump/power steering pump to timing case	Thread not pre-tapped	Nm 35
		Thread pre-tapped	Nm 20
BA46.30-P-1006-01S	Bolt, belt pulley to tandem pump/power steering pump	Nm	30
BA46.30-P-1009-01S	Banjo bolt/union nut high pressure expansion hose (line) to tandem pump/power steering pump	Nm	40

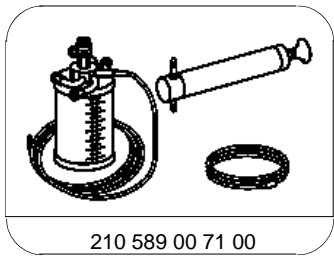

Hand pump