

- MODEL 231
with CODE 487(Active Body Control (ABC))
- MODEL 230
with CODE 487(Active Body Control (ABC))
- MODEL 220
with CODE 487(Active Body Control (ABC))
- MODEL 221
with CODE 487(Active Body Control (ABC))
- MODEL 215, 216

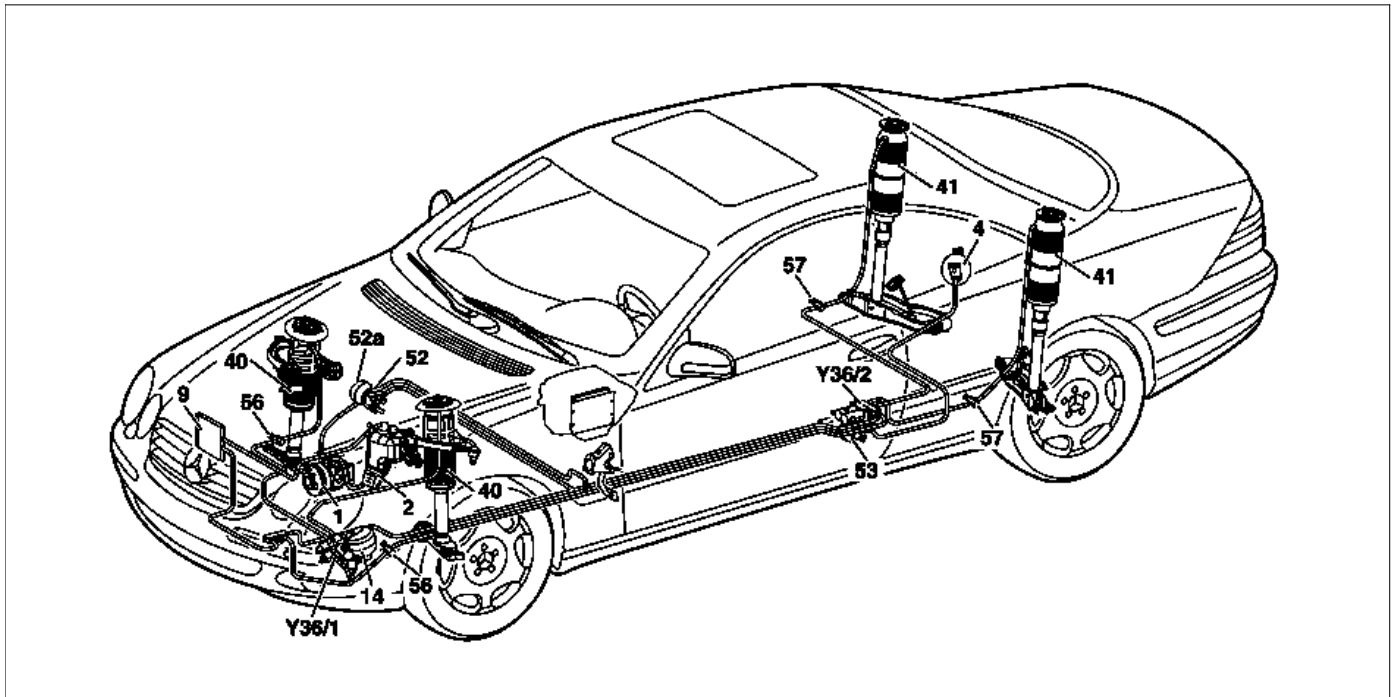

P32.50-2051-09

Shown on model 215

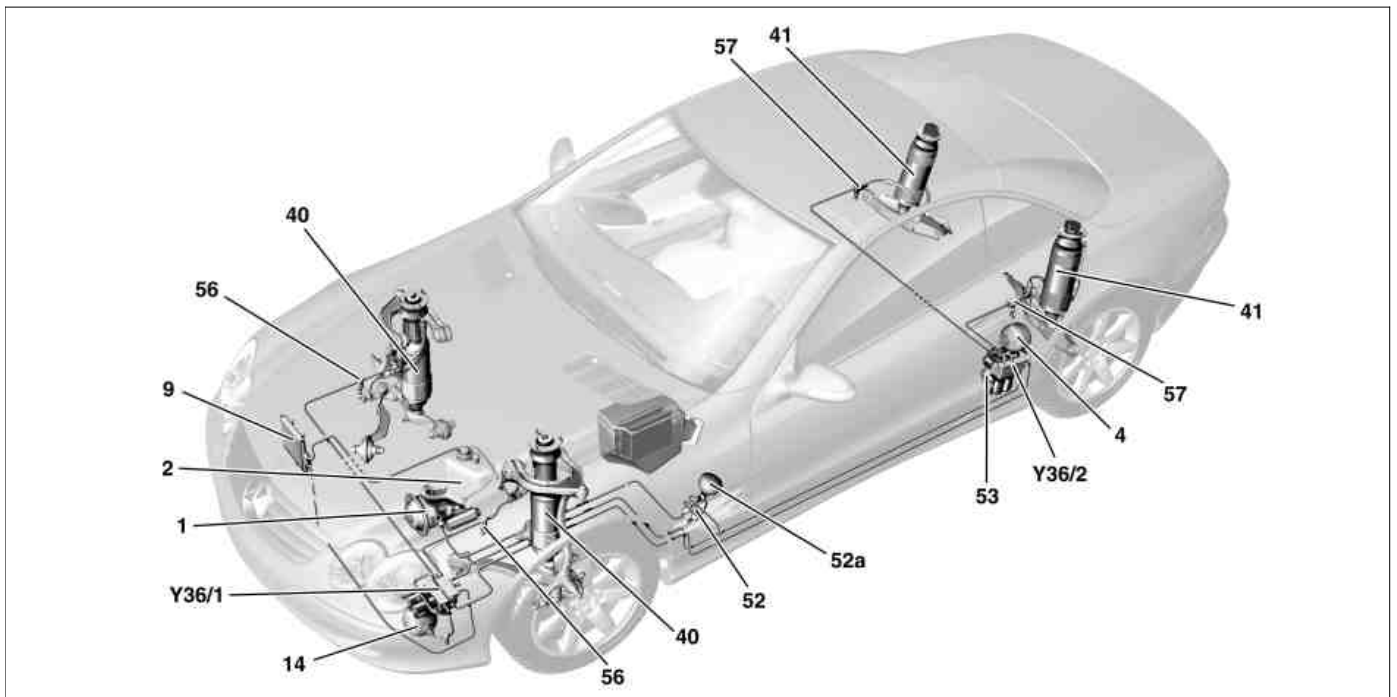

P32.50-2147-09

Shown on model 215 Shown on model 230

1	Tandem pump/hydraulic pump	40	Suspension struts, front	56	Bleed screw
2	Expansion reservoir	41	Suspension struts, rear	57	Bleed screw
4	Rear axle pressure reservoir	52	Pressure supply valve unit	Y36/1	ABC front axle valve unit
9	Oil cooler	52a	Pulsation damper	Y36/2	ABC rear axle valve unit
14	Front axle pressure reservoir	53	Return flow pressure reservoir		

- Always clean the area adjacent to the connections and hose fittings on any and all components being removed prior to starting repair work on ABC systems.

Use caution to ensure that residue and contaminants from repair operations, such as metal shavings, lint, etc., do not enter the ABC system through connections and hose fittings.

- Use the bleed screw (56, 57) to drain the hydraulic fluid, then dispose of the fluid.

ⓘ Carefully open bleed screws (56, 57) so that the hydraulic fluid can flow out slowly.

This helps to prevent the body from lowering too quickly.

- Because even minute particles and traces of contaminants can lead to ABC failure, always pay scrupulous attention to cleanliness when adding hydraulic fluid!
- When bleeding air from the ABC system, and whenever allowing the pump motor to run, always ensure that the fluid reservoir (2) contains an adequate supply of hydraulic fluid, and verify that the tandem pump/hydraulic pump (1) is not aspirating air.

- Adding hydraulic fluid.

The funnel with filter must not be used with other service fluids. To help prevent damage due to dirt entering the ABC system, always store this filter-equipped funnel in a separate cabinet.

- The ABC fluid-return circuit contains a distribution valve with a booster valve and a temperature sensor.
- Before leaving the vehicle parked for extended periods, always bring the front road wheels to their straight-ahead position. Should the ABC system subsequently suffer an internal pressure loss, this precaution will protect vehicle bodywork against contact and possible damage stemming from contact with front wheels that are turned to an angle.