

i The line (F) indicates where the sealant is applied.

i Clean sealing surface. The sealant should be applied only to the indicated surface in the form of a bead of height mm and width 2.0 ± 0.5 mm. The sealant must be applied within 10 min. The silicone bead should not be spread. Only the silicone sealant listed in the section Repair products may be used.

Application of sealant to top part of oil pan

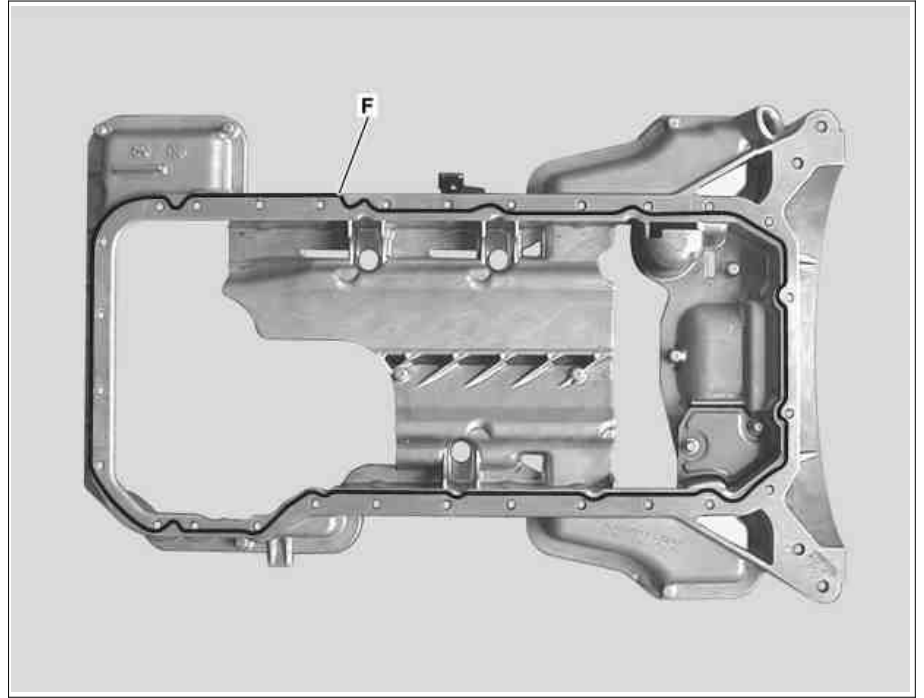

P01.45-2080-06

i The line (F) indicates where the sealant is applied.

i Clean sealing surface. The sealant should only be applied to the indicated surface in the form of a bead of height mm and width 2.0 ± 0.5 mm. The sealant must be applied within 10 min. The silicone bead should not be spread. Only silicone sealant listed in the section Repair products may be used.

Application of sealant to bottom part of oil pan

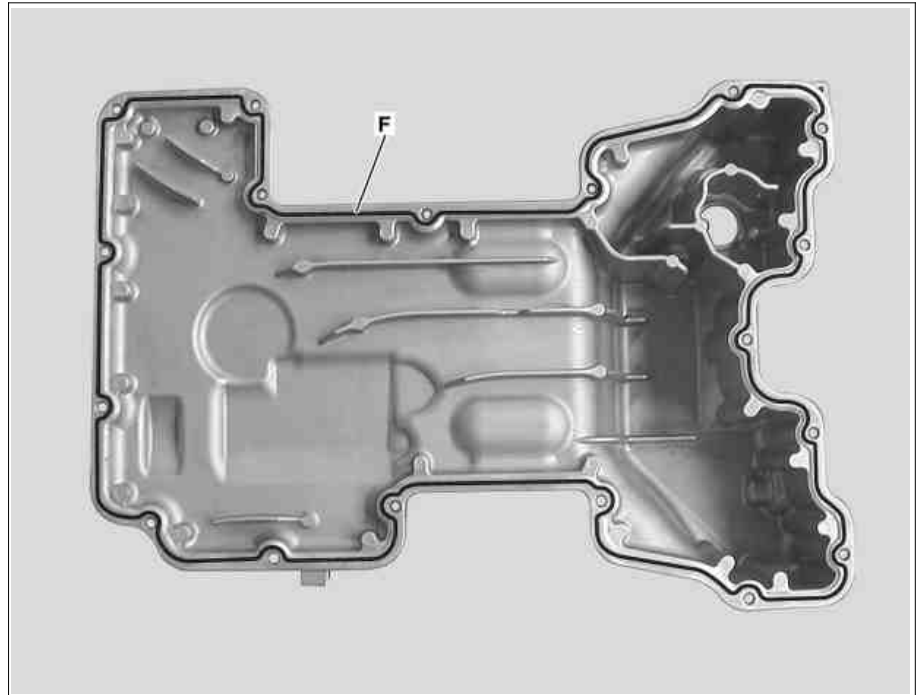

P01.45-2081-06