

ENGINES 112

Air filter positioned on engine side

ENGINES 113 (except 113.995) in MODEL 129, 163, 202, 203, 208, 209, 210, 211, 215, 220, 230

Air filter fitted on motor side

ENGINES 112.945 in MODEL 463.209 /232 /233 /244 /245 /250**ENGINES 113.962 in MODEL 463.206 /240 /241 /247 /248 /249 /254****ENGINES 113.982 in MODEL 463.243 /246**





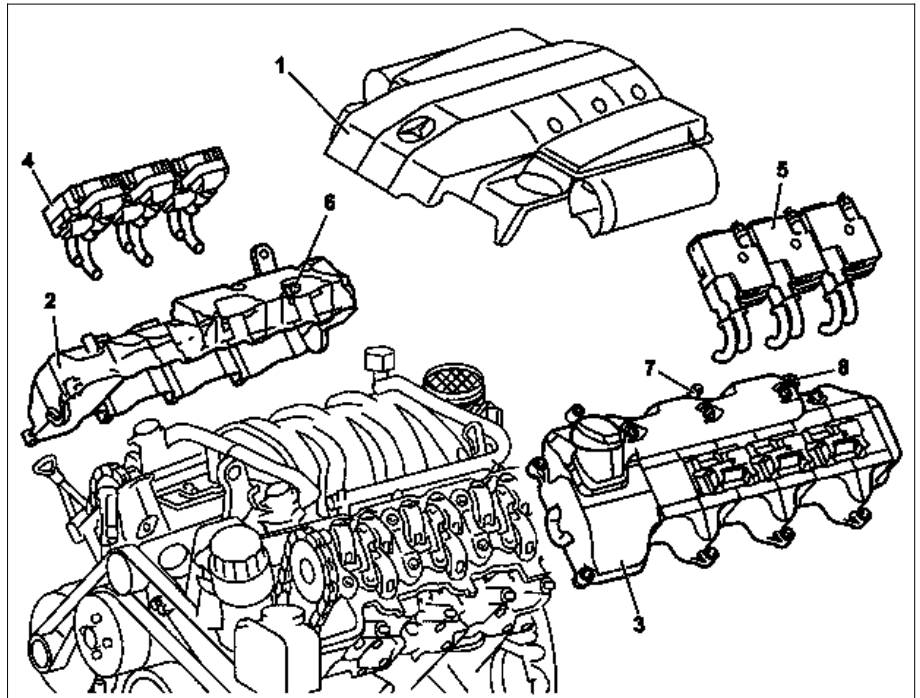

Shown on engine 112.945

- 1 Engine cover with integrated air filter
- 2 Right cylinder head cover
- 3 Left cylinder head cover
- 4 Right ignition coils
- 5 Left ignition coils
- 6 Right connection
- 7 Left connection
- 8 Left connection



P01.30-2024-06

☒ ☒	Remove/install		
1.1	Remove engine trim panel with integrated air filter (1)	i Unclip covering on front side of engine. Remove air filter by pulling vertically up and off the cylinder head covers.	
1.2	Remove air filter	Model 170.466, Model 203.065/265, Model 211.076/276, Model 215.374, 220.074/174, Model 230.474	AR09.10-P-1150SVK
2.1	Unscrew guide tube for the automatic transmission oil dipstick	Except model 170 Model 203, 209.375, Model 208, Model 211.061/065/070, Model 230.475	
3	Detach right ignition coils (4), left ignition coils (5) on right cylinder head cover (2) and left cylinder head cover (3)	Except engines 112.911/914/915/917/954, Engine 113.969	AR15.12-P-2003A
4	Disconnect spark plug connectors	Nm i Installation: Observe marking for spark plug connectors on the cylinder head covers and ignition coils. ☒ Double open-ended wrench	*BA01.20-P-1002-01E *110589010100
5	Pull off vent hoses on right connector (6) and on left connector (7) of the right cylinder head cover (2) and left cylinder head cover (3)		
6	Pull off engine vent hose on left connector (8) of left cylinder head cover (3)		
⚠ Danger! 7.1	Risk of explosion caused by fuel igniting, risk of poisoning caused by inhaling and swallowing fuel and risk of injury to eyes and skin caused by contact with fuel Disconnect fuel line at fuel rail	No fire, sparks, open flames or smoking. Only pour fuels into suitable and appropriately marked containers. Wear protective clothing when handling fuel. i Only on vehicles with rigid fuel line and: Model 211.061/065/070/076/276, Model 215.374, Model 220.074, Model 230.474/475	AS47.00-Z-0001-01A

		Release fuel pressure through service valve!  Engine 112  Engine 113  Pressure hose	*BA07.52-P-1001-01A *BA07.52-P-1001-01A *119589046300
8	Remove right cylinder head cover (2) and left cylinder head cover (3)	 Installation: Check cylinder head covers for leaks, see: ↓ Ensure cylinder head cover gasket is correctly installed 	AR01.20-P-5014-01B *BA01.20-P-1001-01E
9	Install in the reverse order		
 Danger!	Risk of accident caused by vehicle starting off by itself when engine is running. Risk of injury caused by contusions and burns during starting procedure or when working near the engine as it is running	Secure vehicle to prevent it from moving by itself. Wear closed and snug-fitting work clothes. Do not touch hot or rotating parts.	AS00.00-Z-0005-01A
10	Check for leaks with engine running		

 **Crankcase ventilation, cylinder head cover**

Number	Designation			Engine 112	Engine 113
		Stage 1	Nm	9	9
BA01.20-P-1001-01E	Cylinder head cover bolt	Stage 1	Nm	9	9
		Stage 2	∠°	-	-
BA01.20-P-1002-01E	Bolt, ignition coils to cylinder head cover		Nm	8	8

 **Fuel distributor**

Number	Designation			Engine 112 except 112.945/951/960/961	Engine 112.945	Engine 112.960/961 AMG
		Nm	38	38	35	
BA07.52-P-1001-01A	Fuel feed line to fuel distributor	Nm	38	38	35	

 **Fuel distributor**

Number	Designation			Engine 113.940/941/942/943/944/945/946/948/960/961/962/963/964/965/966/967/968/969/971/980/981/982/984/986/988	Engine 113.987	Engine 113.990/991	Engine 113.992/993/995
		Nm	38	38	38	38	
BA07.52-P-1001-01A	Fuel feed line to fuel distributor	Nm	38	38	38	38	

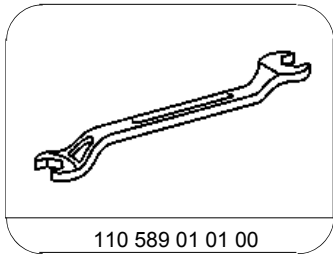

110 589 01 01 00

Open-end wrench, double

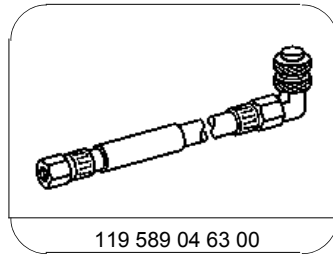

119 589 04 63 00

Pressure hose