

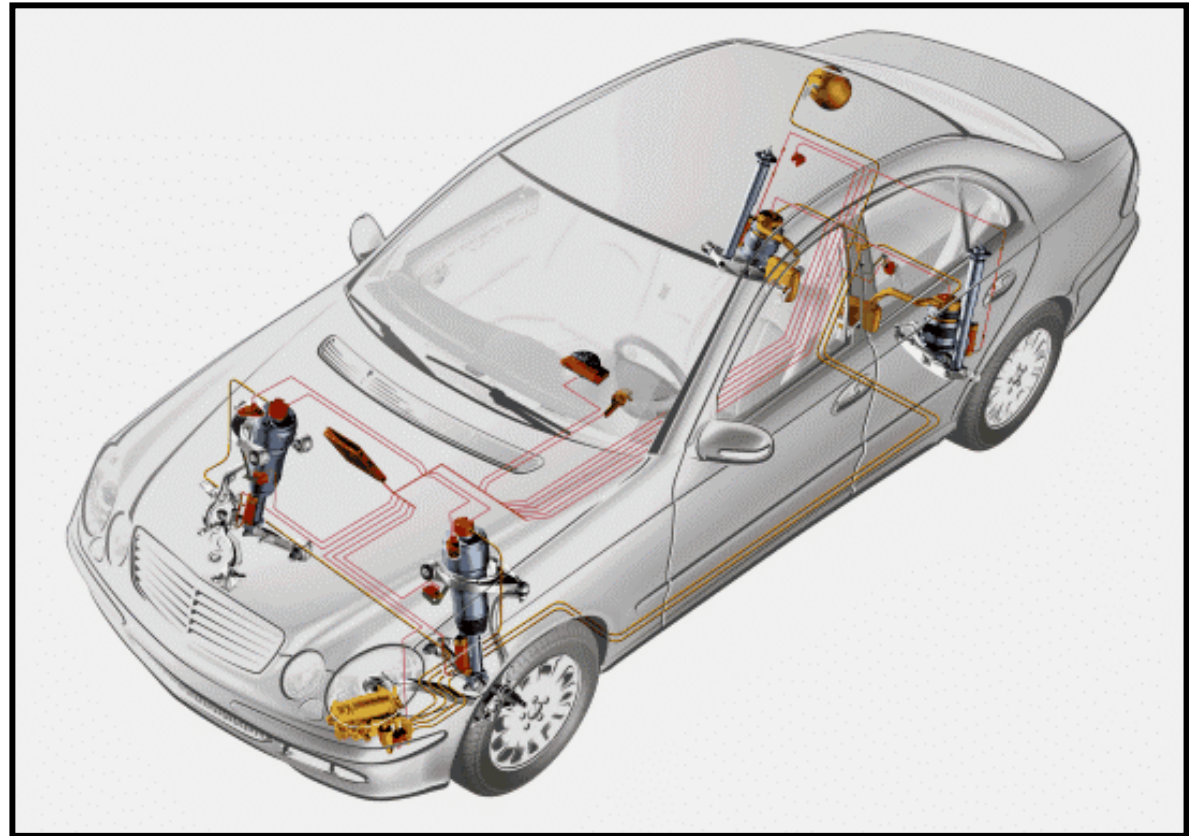

Mercedes-Benz

# Semi-Active Air Suspension (SAS)



Std E500 (optional E320)

These technical training materials are current as of the date noted on the materials, and may be revised or updated without notice. Always check for revised or updated information.

To help avoid personal injury to you or others, and to avoid damage to the vehicle on which you are working, you must always refer to the latest Mercedes-Benz Technical Publication and follow all pertinent instructions when testing, diagnosing or making repair. Illustrations and descriptions in this training reference are based on preliminary information and may not correspond to the final US version vehicles. Refer to the official introduction manual and WIS when available.

*Copyright Mercedes-Benz USA, LLC, 2002*

*Reproduction by any means or by any information storage and retrieval system or translation in whole or part is not permitted without written authorization from Mercedes-Benz USA, LLC or its successors.*

*Published by Mercedes-Benz USA, LLC*

*Printed in U. S.A.*

# SAS Advantages

- Improved driving safety and ride comfort due to:
  - Suspension ride height adaptation to vehicle load
  - Suspension dampening adaptation to road and driving style
  - Lower center of gravity (speed dependent)
  - Less aerodynamic drag (improved MPG)
  - Less up force on the front axle (anti-squat at rear axle)
- Driver control of:
  - Vehicle level
  - Dampening
- Driver information:
  - Vehicle raised function indicator lamps in switch
  - Sport dampening function indicator lamps in switch
  - Multi-function display of warning messages

# SAS Function

- SAS Dual Control System
  - Air suspension leveling
  - Air suspension dampening

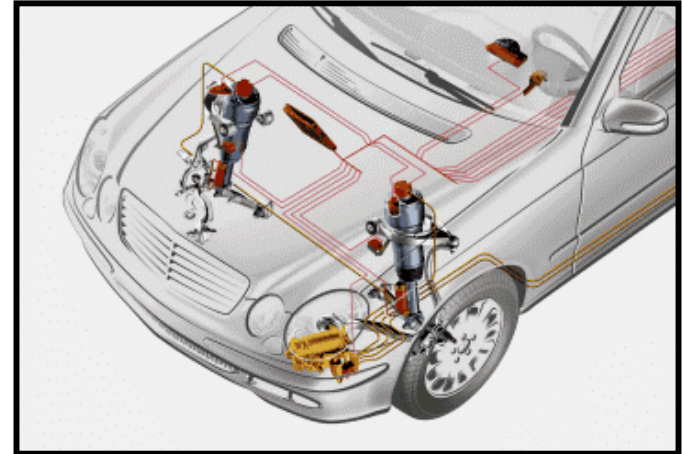

- ADS II
  - Hydraulic dampening



# Front Air Spring / Strut

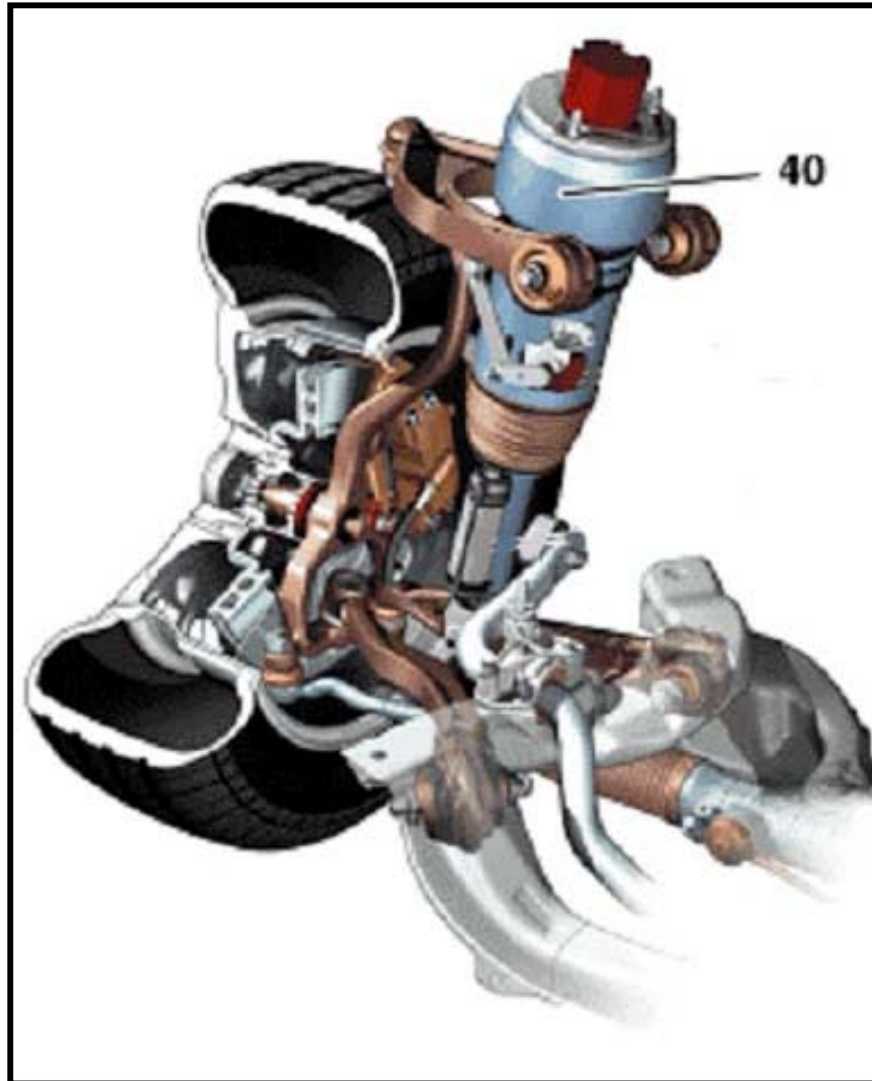

# Front Air Spring Construction

- 40** Front air spring / strut
- Y51/1** LF spring strut valve unit
- y1** Additional volume valve
- y2** Level valve
- p** Additional volume air chamber
- i** Stop buffer
- l** Air chamber
- e** Piston rod
- h** Air bellows
- n** Protective boot
- v** Shock absorber
- Y51** LF front axle dampening valve

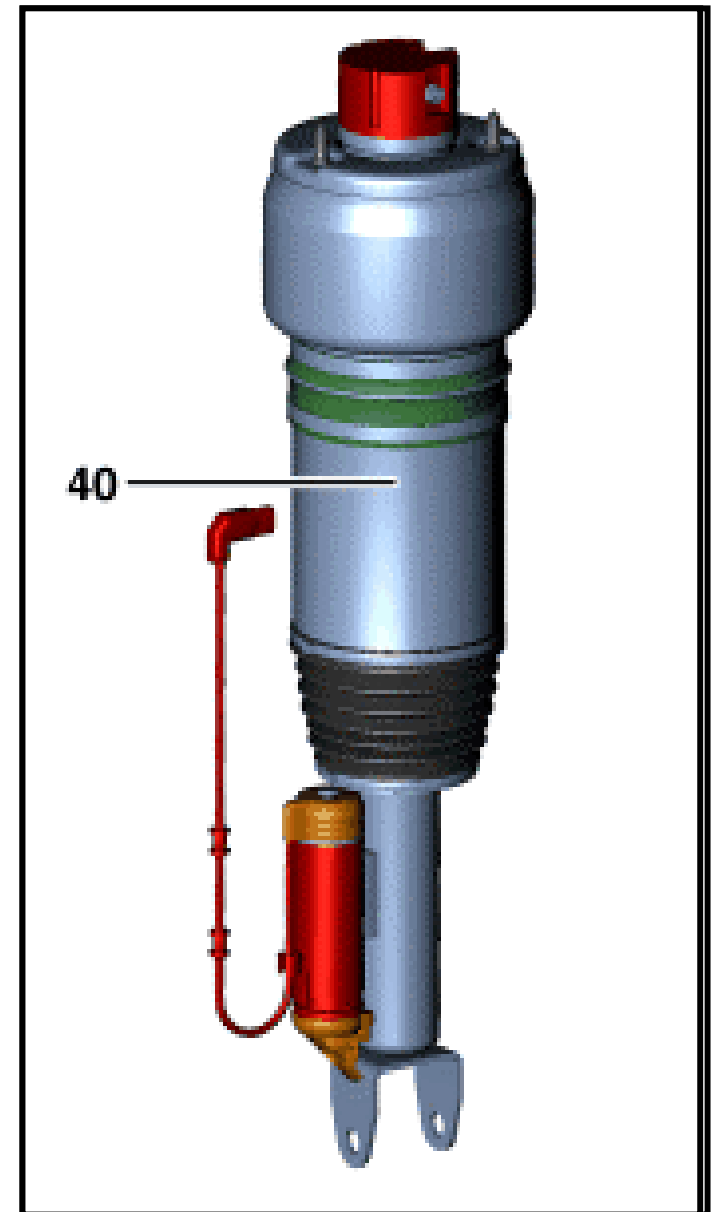

# Level and Height Adjustment (y2)

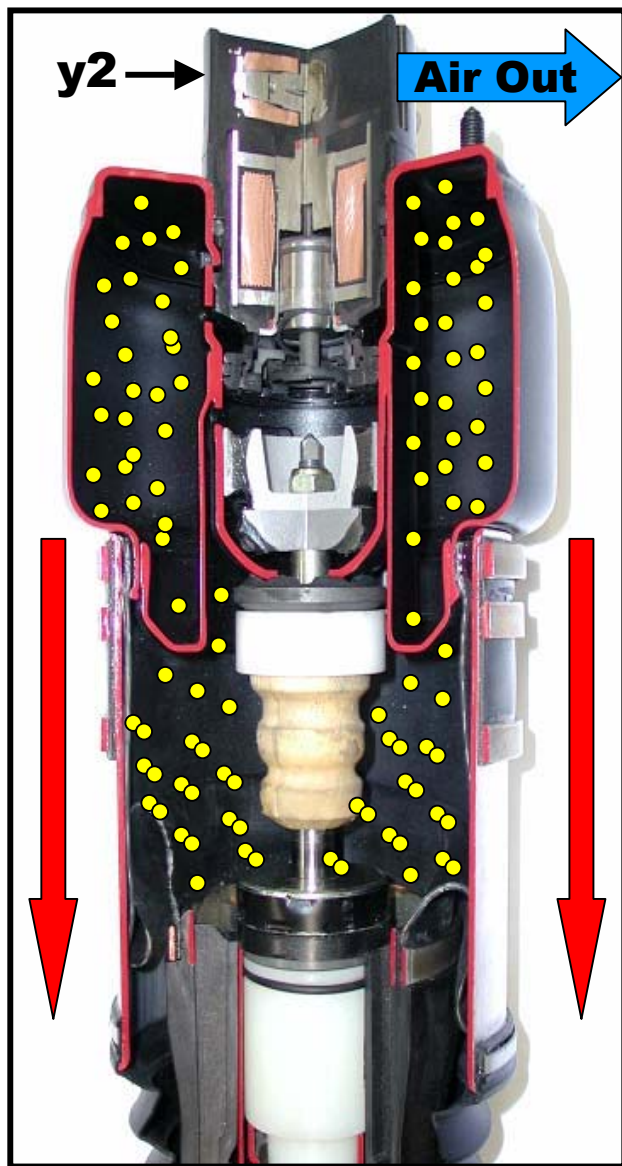

Lower

Solenoid (y2) energized (open) for ride height changes

Note:

Closing y2 acts as the check valve. This will maintain air volume in spring / strut assembly.

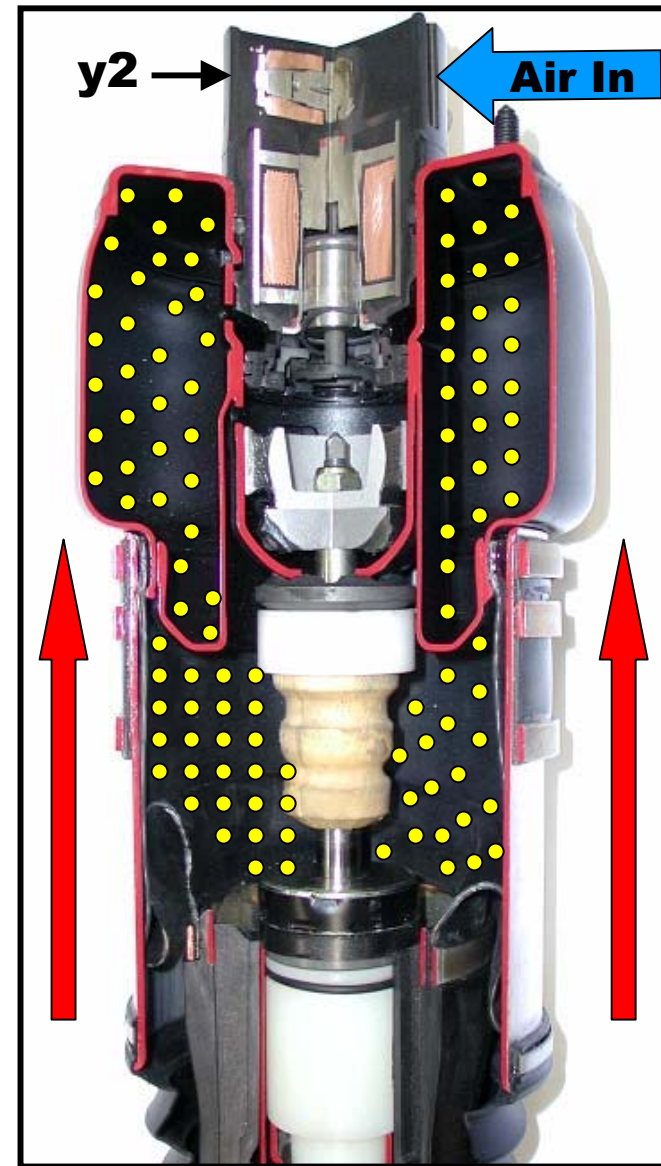

Raise

# Air Spring Dampening (y1)

y1

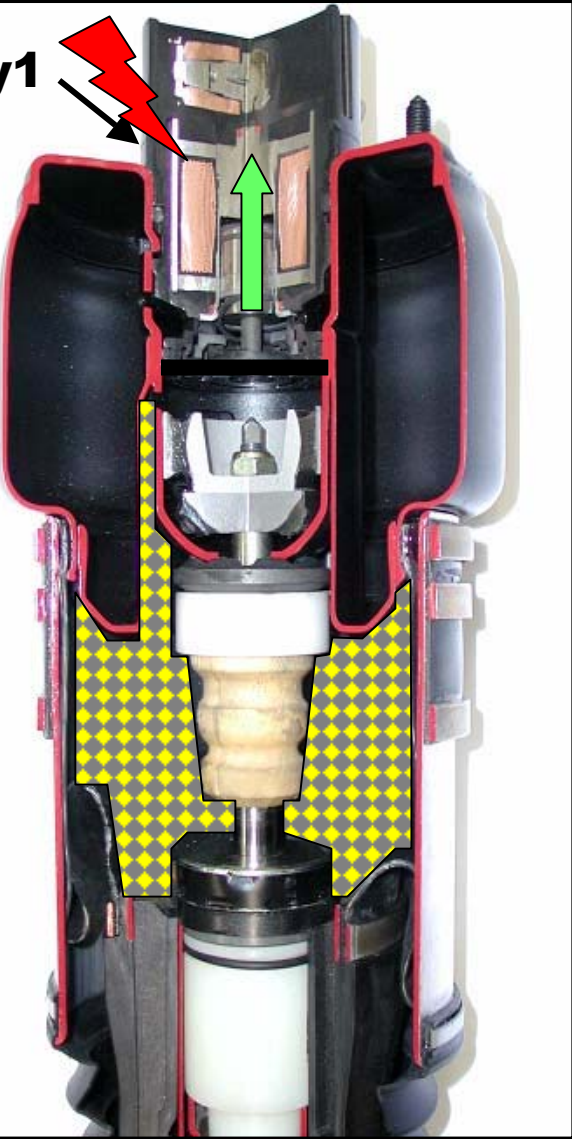

Solenoid (y1) closed  
(energized)  
one air chamber used,  
less air volume to  
compress = firmer

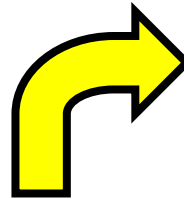
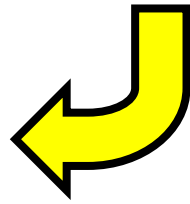

Solenoid (y1) open  
(de-energized)  
both air chambers  
used, more air volume to  
compress = softer

y1

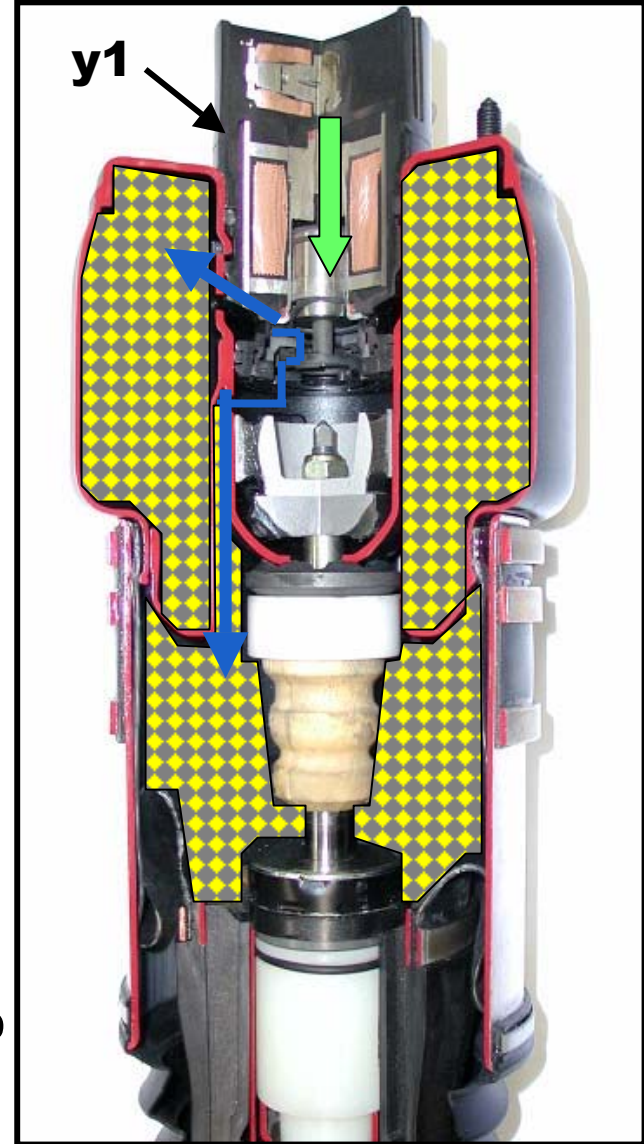



# Rear Air Spring / Strut

- 41** - Rear air spring / strut
- 5** - Rear dampening shock
- Y53** - Rear ADS dampening valve

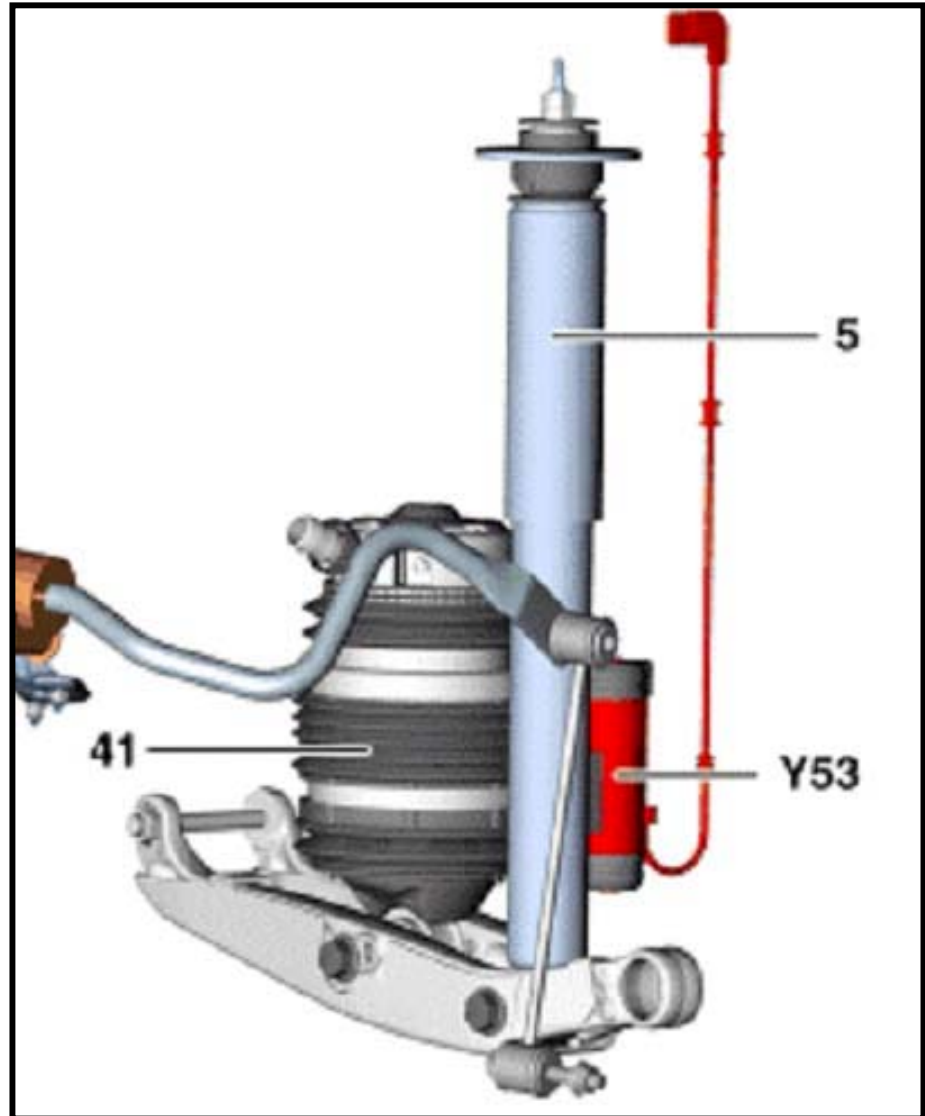

# Rear Air Spring / Strut Construction

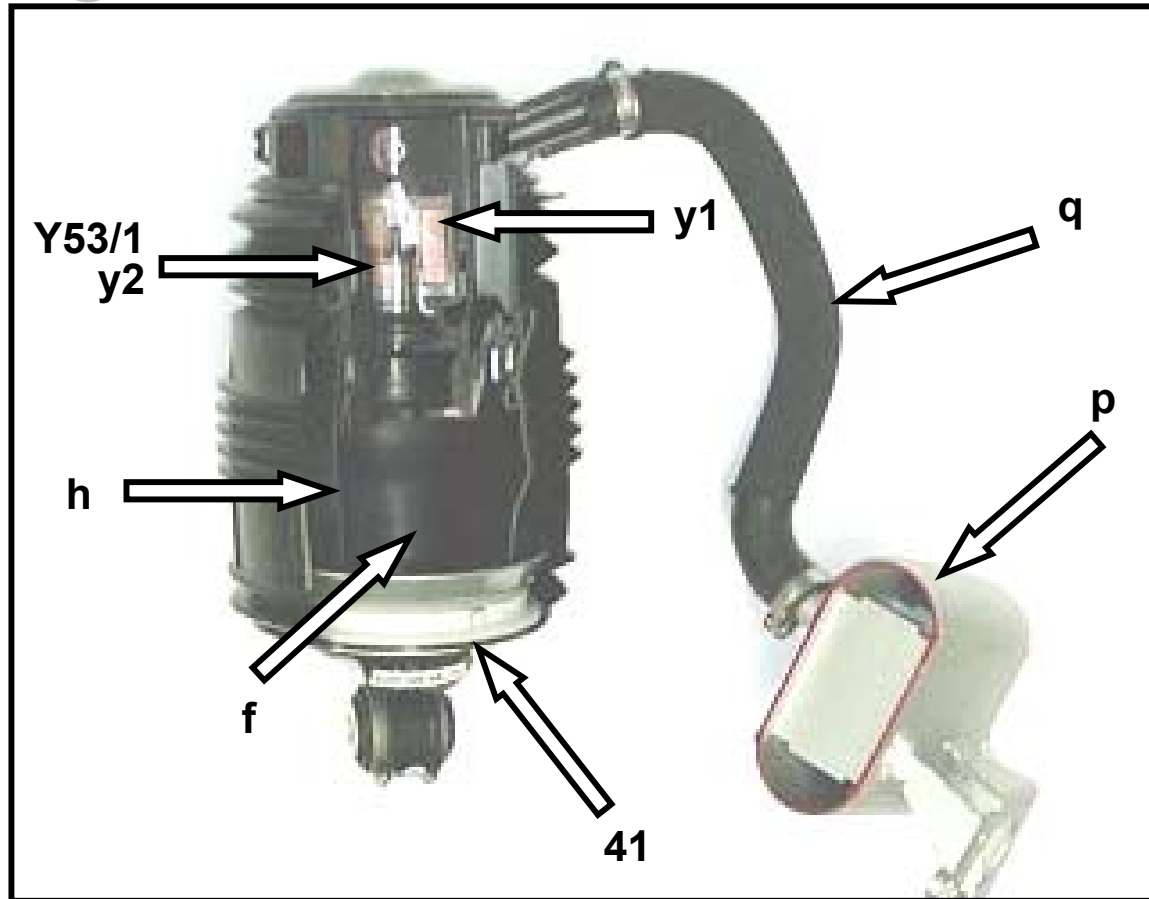

41 - Rear air spring / strut

h - Air bellows

f - Air chamber

p - Additional volume air chamber

q - Connecting hose

Y53/1 - LR spring strut valve unit

y1 - additional volume valve

y2 - level valve

# SAS Pneumatic / Hydraulic Components

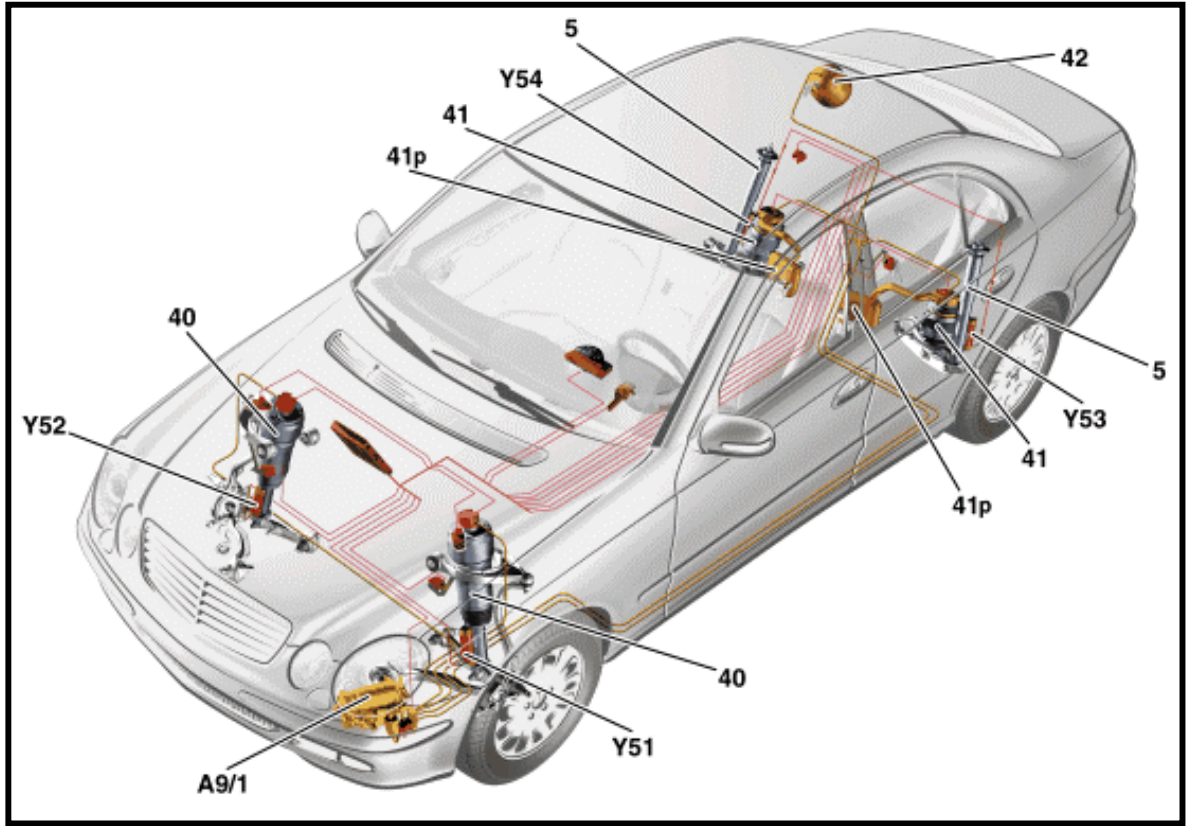

A9/1 - SAS compressor unit

40 - Front air spring strut

41 - Rear air spring strut

41p - Rear air spring additional volume reservoir

42 - SAS central reservoir

Y51, 52, 53, 54 - ADS dampening valves

5 - Rear shock absorber

# SAS Compressor Unit (A9/1)

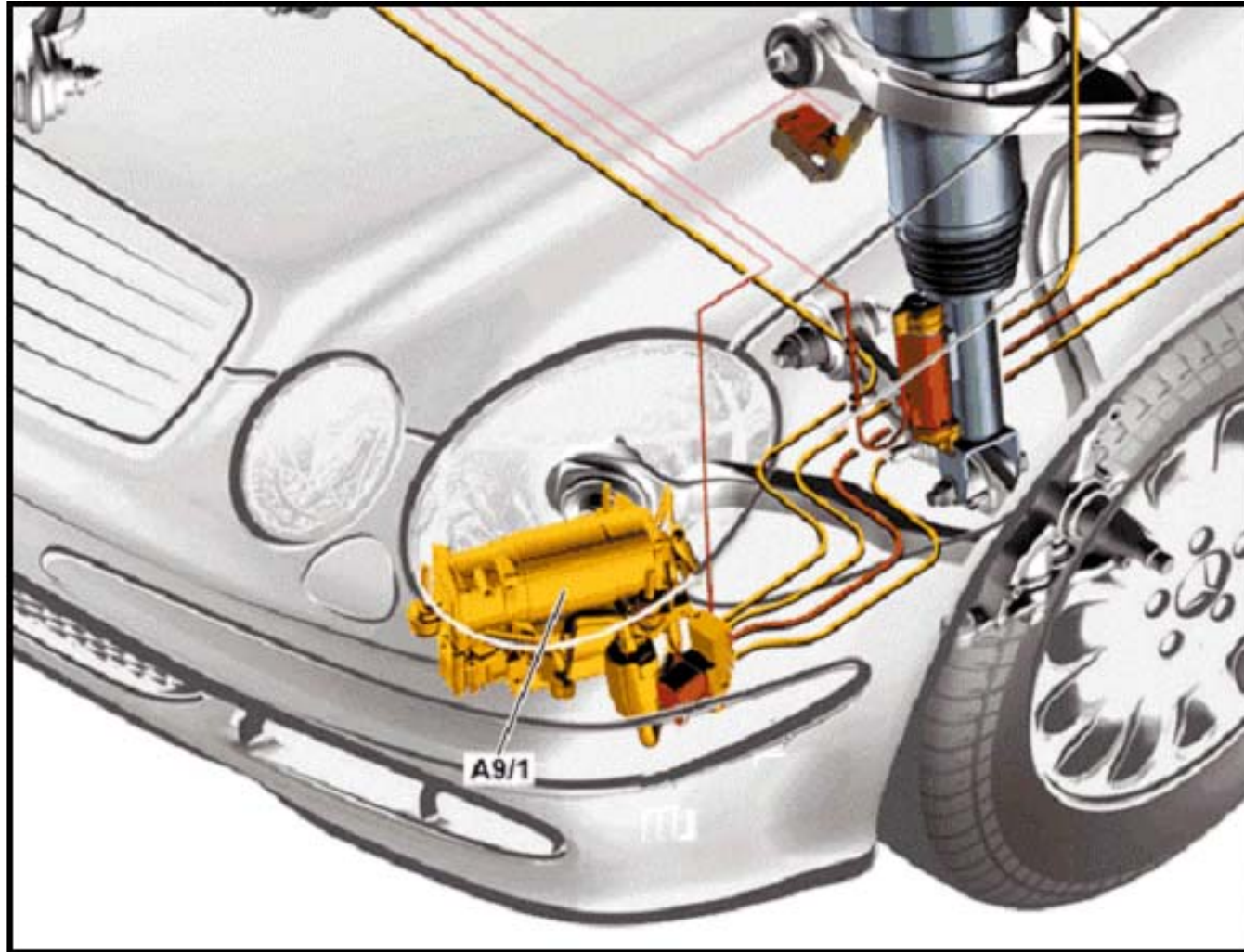

Location: Left front wheel housing

# Central Reservoir Charge Valve (Y36/6)

Y36/6 - Central reservoir charge valve

B7 - Central pressure sensor

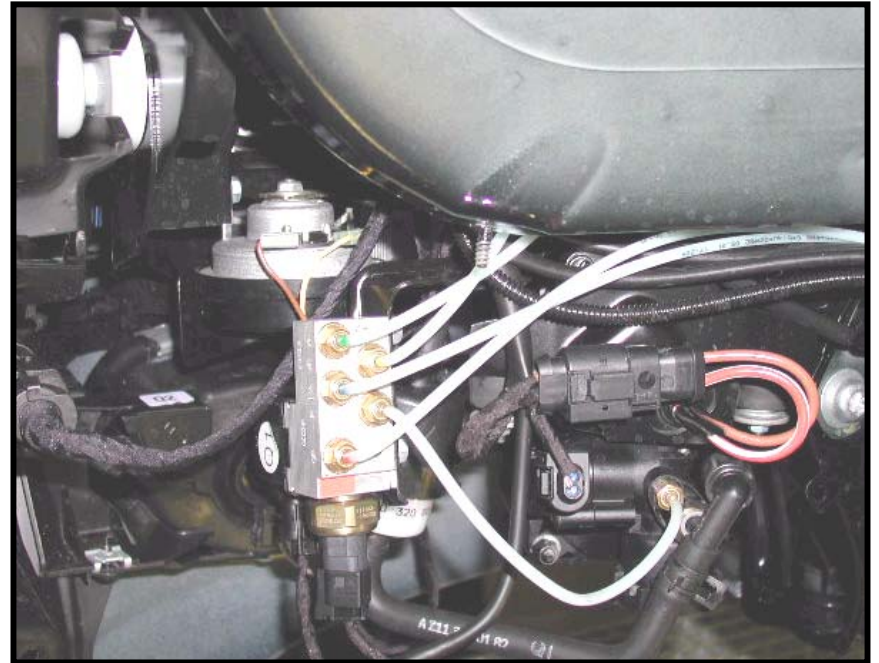
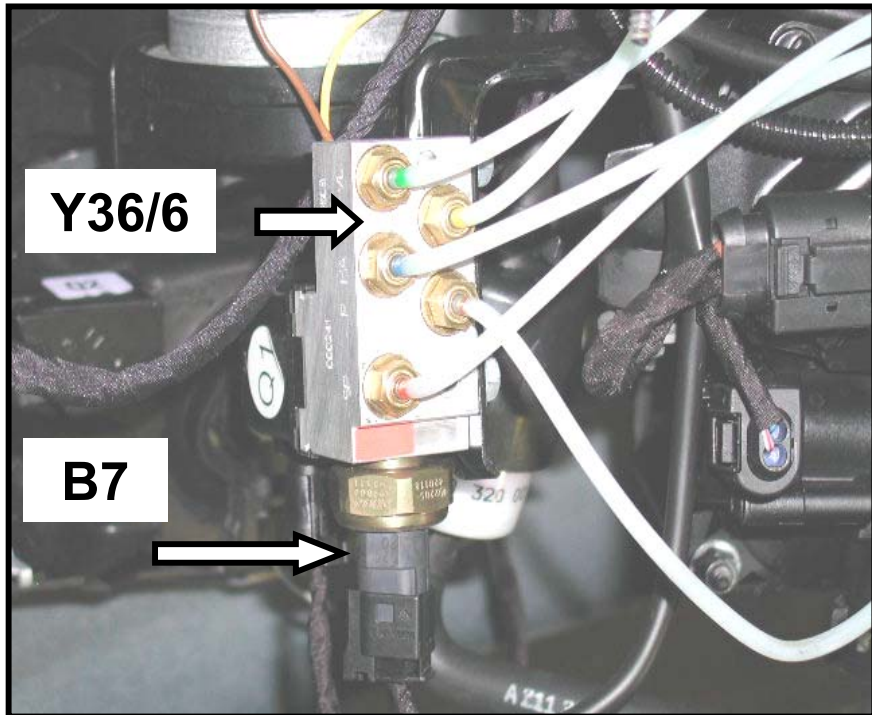

Location: Under left front headlamp

# SAS Function Diagram

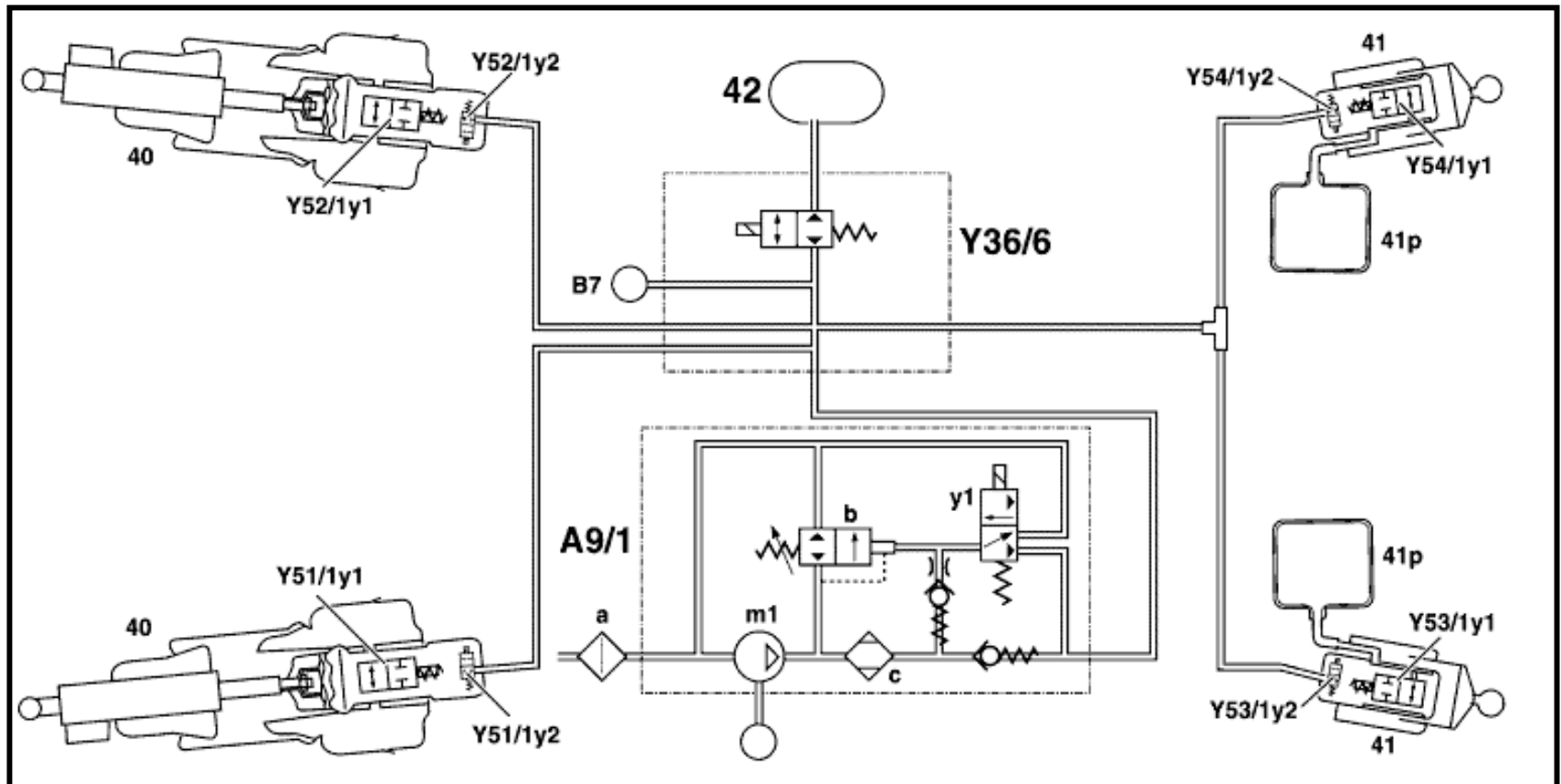

# SAS Function Diagram / Legend

## **A9/1 SAS compressor unit**

- m1 compressor motor
- y1 compressor fill / vent valve
- b pressure relief valve (~21 bar)
- c drier
- a filter

## **Y36/6 Central reservoir solenoid valve**

- b7 SAS pressure sensor

## **40 Front air spring strut**

- Y51/1y1, Y52/1y1 air dampening solenoid
- Y51/1y2, Y52/1y2 level solenoid

## **41 Rear air spring strut**

- Y53/1y1, Y54/1y1 air dampening solenoid
- Y53/1y2, Y54/1y2 level solenoid

## **41p Rear air spring additional volume reservoir**

## **42 SAS central reservoir**

# SAS Electrical Components

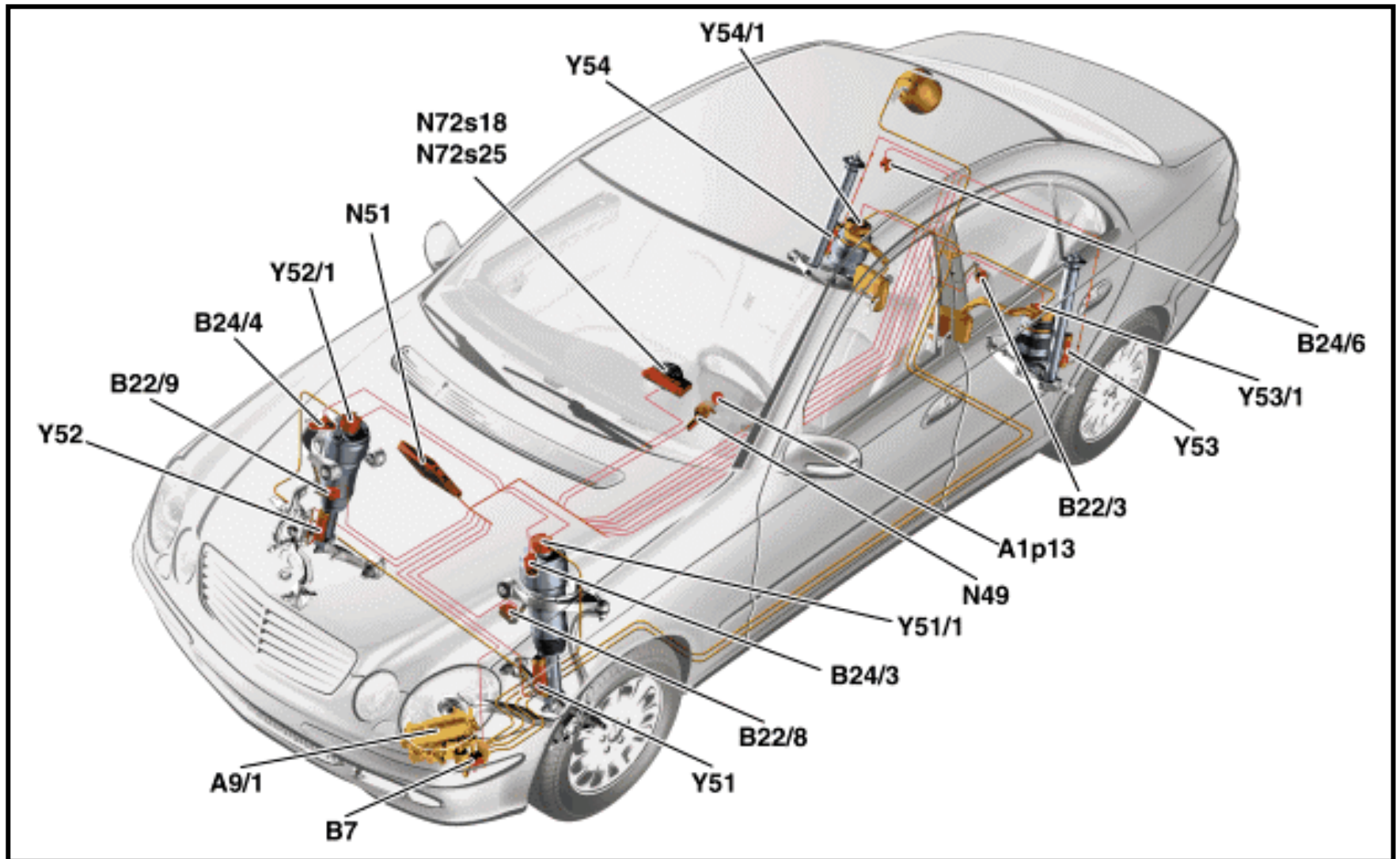



# Electrical Components / Legend

A1p13 - IC multifunction display

A9/1 - SAS compressor unit

B7 - SAS pressure sensor

B22/3 - Rear level sensor

B22/8 - LF axle level sensor

B22/9 - RF axle level sensor

B24/3 - LF body acceleration sensor

B24/4 - RF body acceleration sensor

B24/6 - Rear body acceleration sensor

N49 - Steering angle sensor

N51 - SAS control module

N72s18 - Level adjustment switch

N72s25 - Comfort / sport switch

Y51 - LF ADS dampening valve

Y51/1 - LF SAS valves

Y52 - RF ADS dampening valve

Y52/1 - RF SAS valves

Y53 - LR ADS dampening valve

Y53/1 - LR SAS valves

Y54 - RR ADS dampening valves

Y54/1 - RR SAS valves

# SAS Control Module (N51)

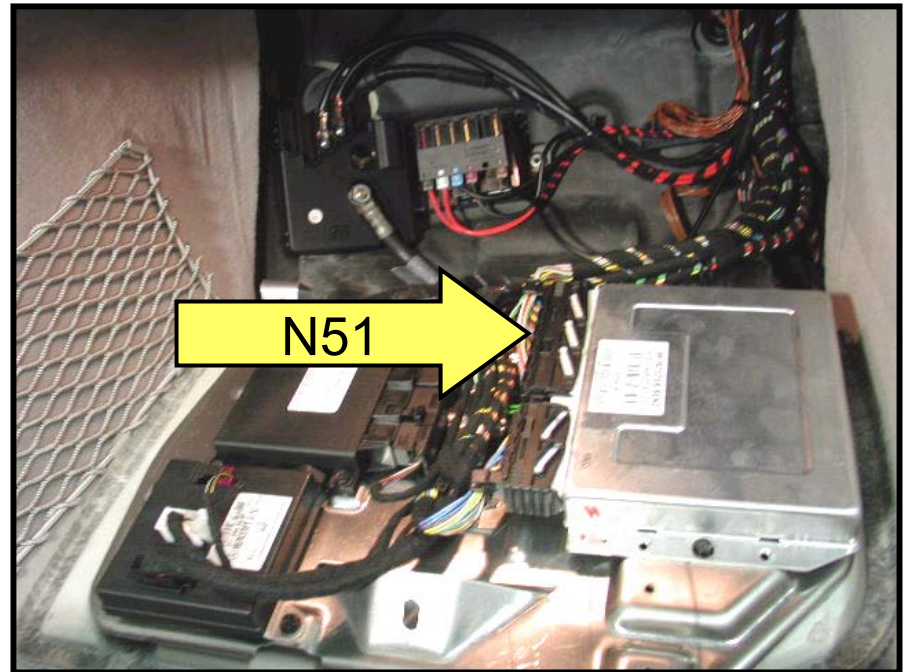
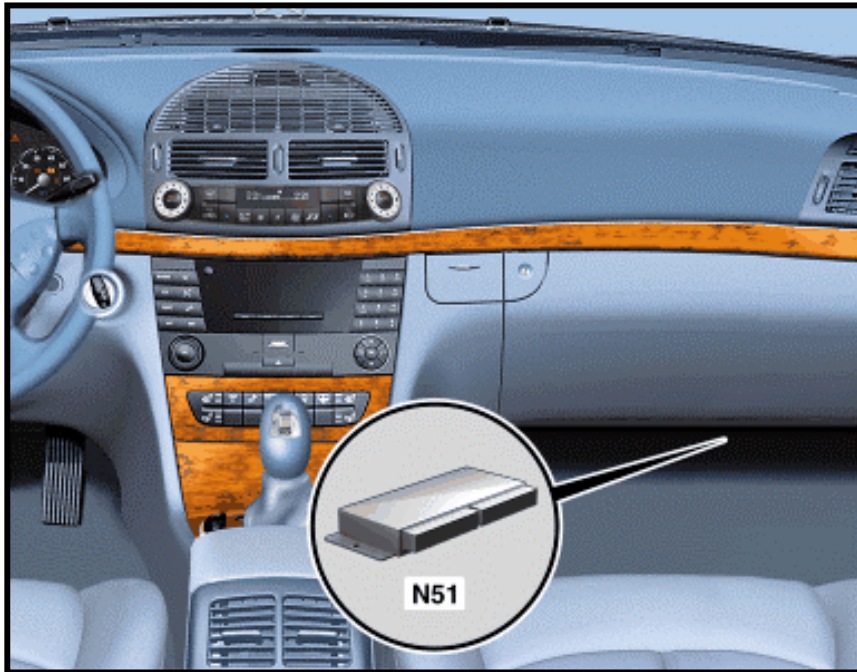

Location: Passenger footwell

# SAS Wake-Up Function

Wake-up causes SAS module (N51) to monitor vehicle ride height and adjust as needed dependent on vehicle load changes.

Wake-up occurs with any one of the following inputs:

- EIS key activation
- Any door activation
- Trunk lid activation
- Park brake activation
- Stop lamp switch activation

# Vehicle Level Notes

## Wake-up Function

- if level is  $>30\text{mm}$  lower than normal ( $0\text{mm} \pm 10$ ) it will raise to normal level (if reservoir pressure  $>11$  bar)
- if level is  $>65\text{mm}$  lower than normal, it will be raised even with a reservoir pressure of  $<11$  bar by the compressor (prerequisite battery voltage  $>12.5\text{v}$ ) to  $-63\text{mm}$  (critical level)
- if level is  $>10\text{mm}$  higher than normal, it will be lowered to normal

## Normal Function (engine running)

- level will be corrected if level deviates  $>10\text{mm}$  after opening a door or trunk
- while driving, the vehicle level will adjust if deviation  $>20\text{mm}$
- while driving, every 15 minutes the level is adjusted to within  $\pm 10\text{mm}$  of normal ride height

## Locking Function

- if wheels are unloaded when vehicle stationary, strut valves remain closed

# Front Level Sensors (B22/8,9)

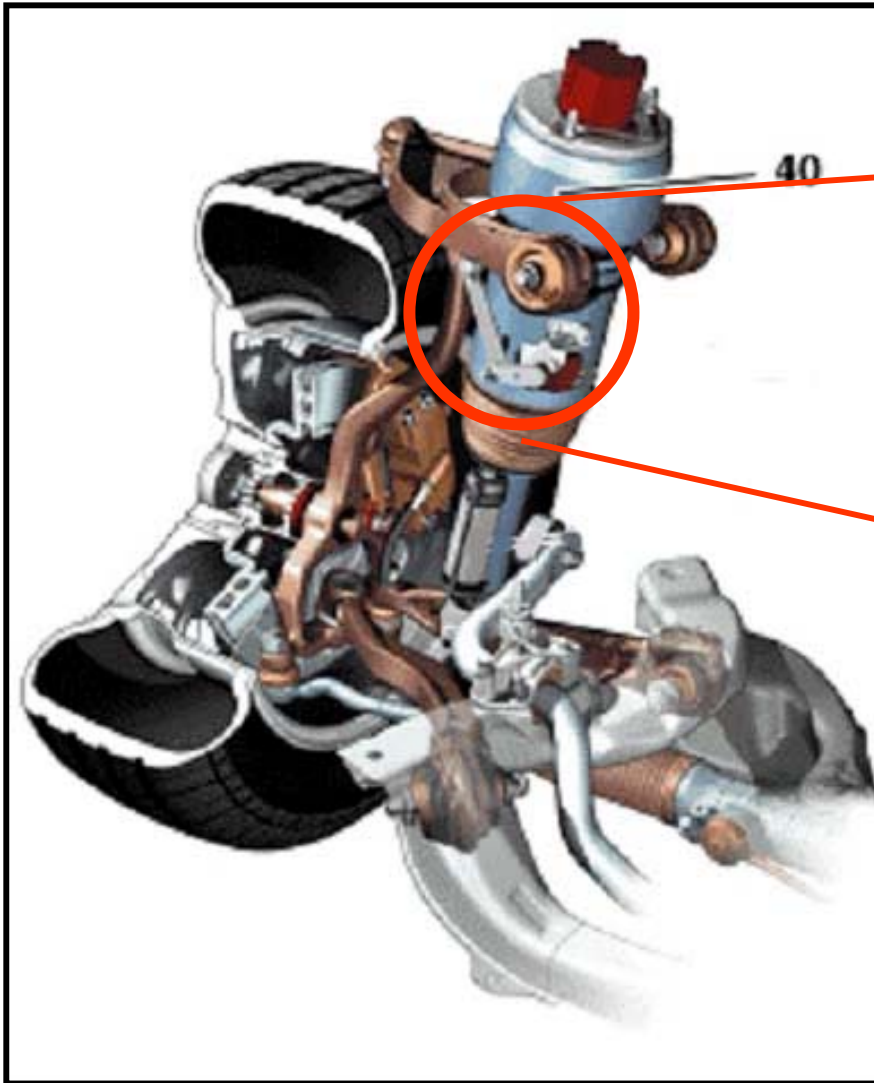

Each sensor contains:

- 2 Hall effect sensors
- Redundant signal

Location: Front upper control arm

# Rear Level Sensor (B22/3)

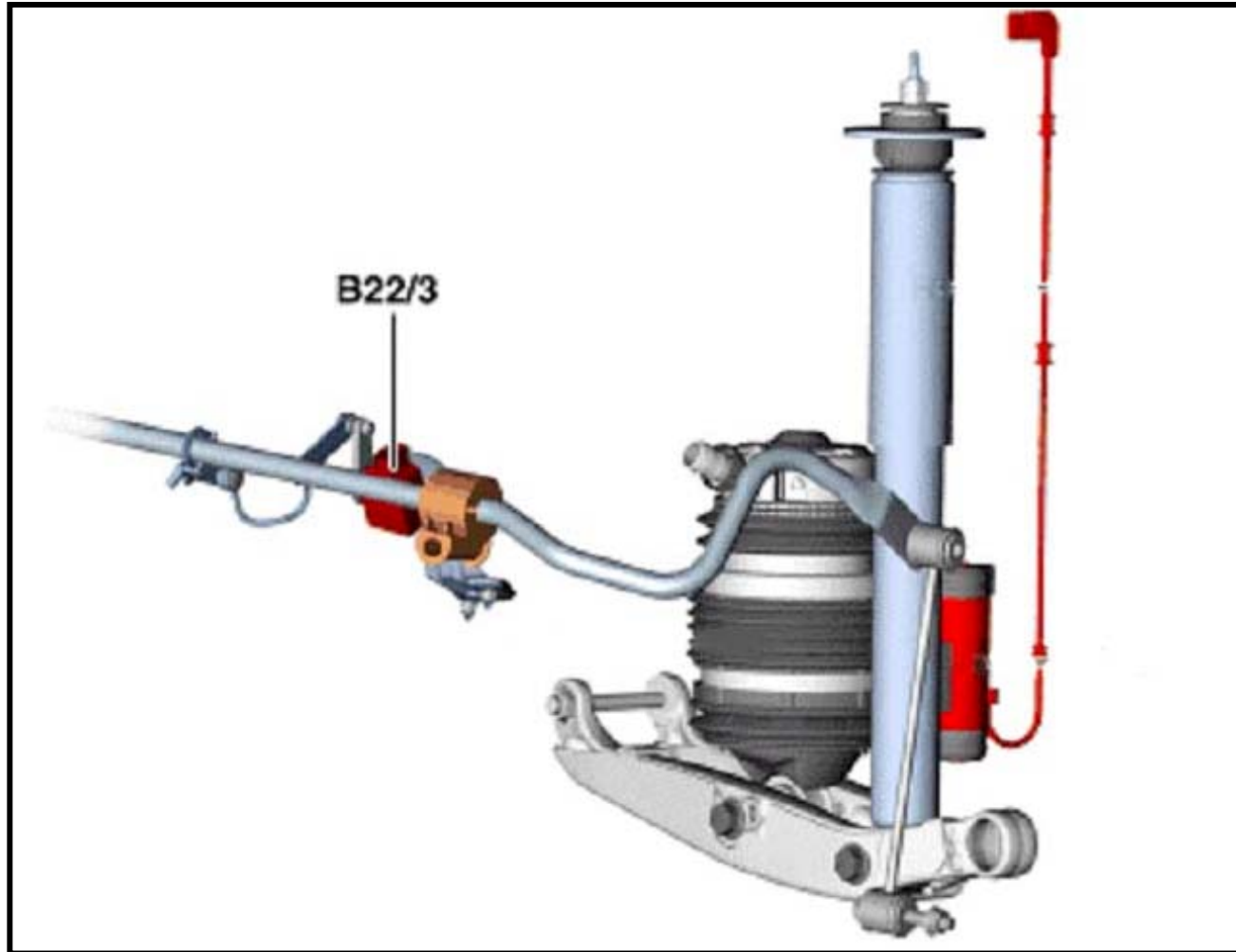

Location: Rear stabilizer bar

# Body Acceleration Sensors (B24/3,4,6)

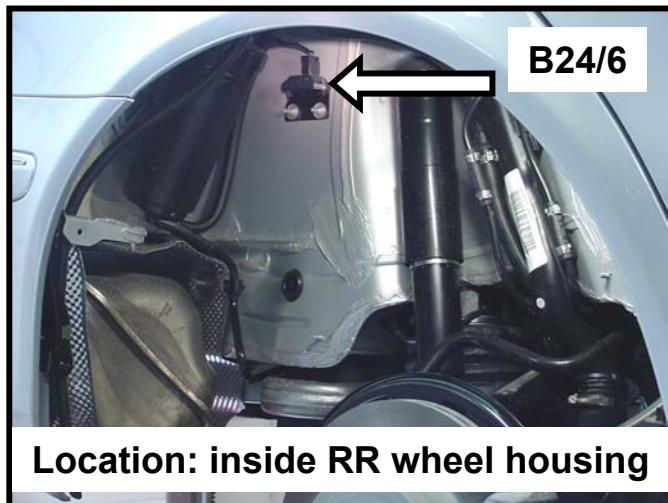
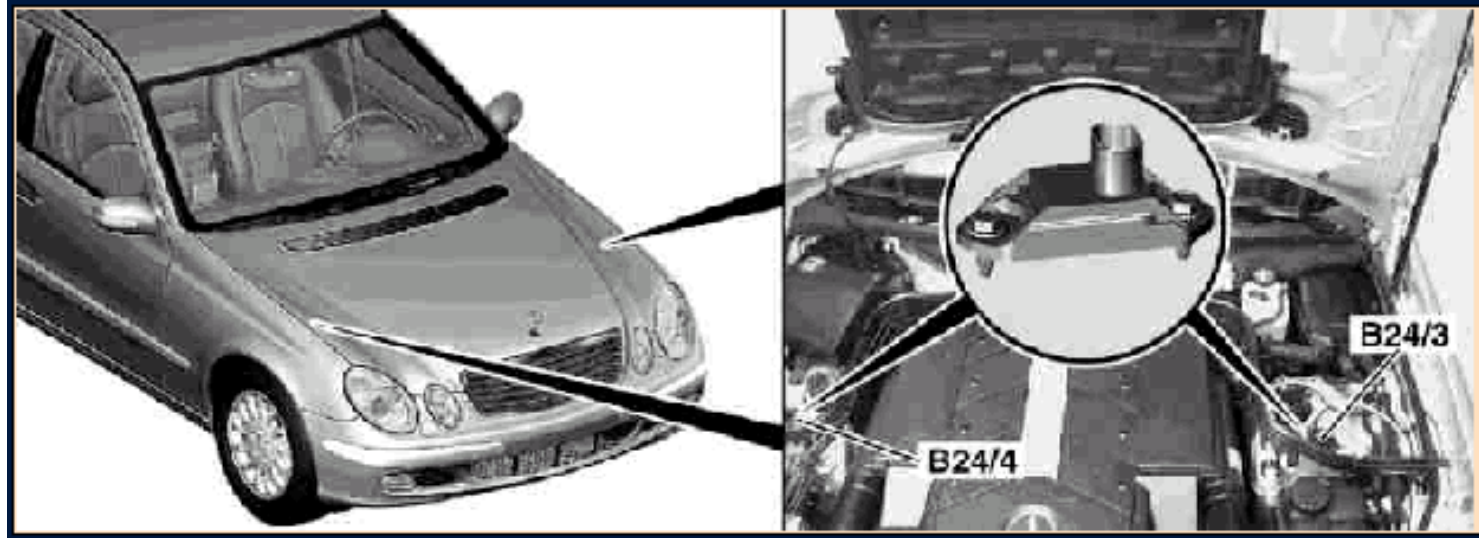

- Measures vertical oscillations of the chassis
- Translates mechanical movements into voltage signals
- Influences ADS II dampening functions

# Level Adjustment Switch (N72s18)

- Raises the vehicle above normal level
- Wired to LCP (N72)
- Input to SAS (N51) via CAN B
- N72 controls LED activation





# Level Adjustment Parameters

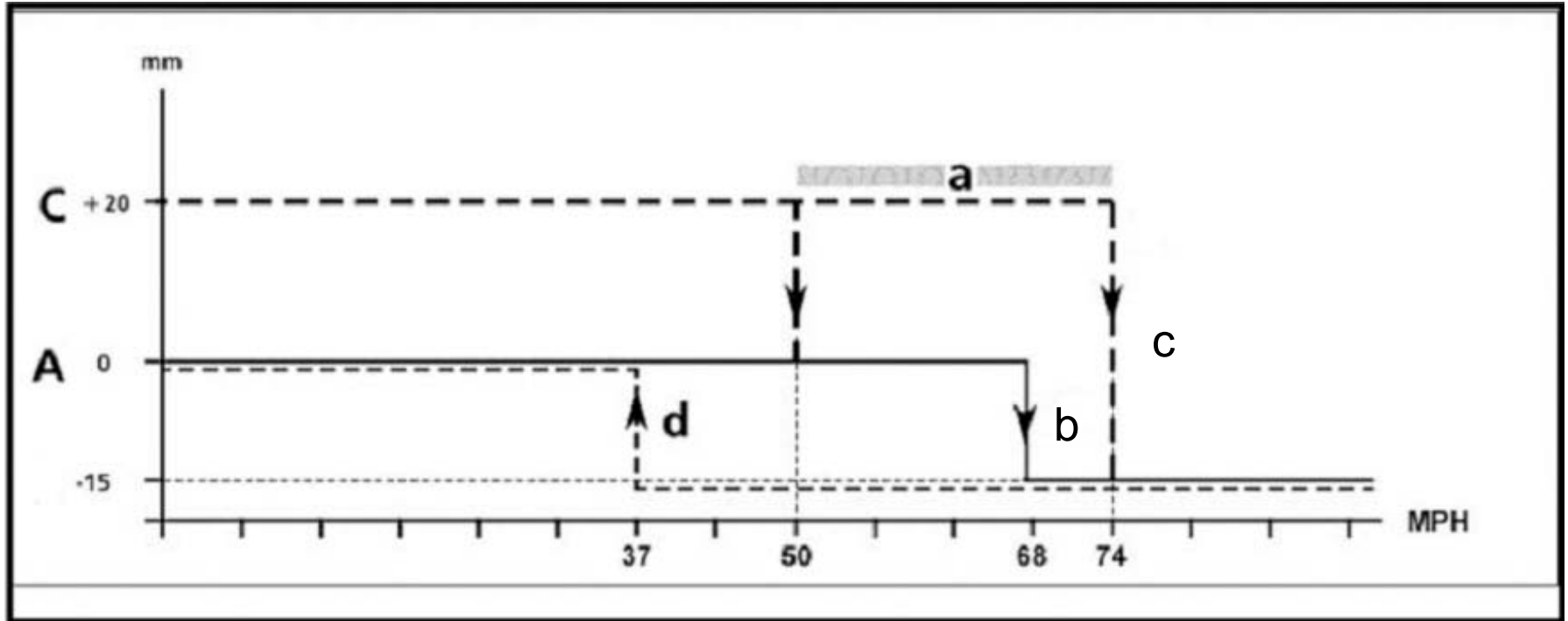

A - Normal ride height up to 68 mph, then lowers (b) to -15mm

d - vehicle height will rise to normal height at 37 mph

C - Raised ride height (+20mm).

a - lowers to -15mm if vehicle speed between 50 and 74 mph for 5 minutes

c - lowers to -15mm if vehicle speed greater than 74 mph

Note: Raised height cancelled once vehicle lowered.

# ADS II

In addition to the two stages of dampening (air volume) that the SAS air suspension system provides, the ADS II system adds another four stages of dampening (hydraulically).

Under normal driving conditions the SAS control module will control the dampening stages automatically based on sensor inputs.

Driver can manually choose different stages by pressing the Comfort / Sport switch (N72s25) next to the gear shifter.



# ADS II Comfort / Sport Switch (N72s25)

- LED's off, comfort setting
- Sport setting #1
  - 1 LED illuminated
  - SAS reduced air dampening volume (firmer)
  - ADS II dampening controlled automatically
- Sport setting #2
  - 2 LED's illuminated
  - SAS reduced air dampening volume (firmer)
  - ADS II, stage 3 or 4 dampening, as required
- Wired to LCP (N72)
- Input to SAS (N51) via CAN B
- LCP (N72) controls LED activation



# ADS II Shock Absorber



Movement



Oil flow

# 211 SAS vs. 220 AIRmatic Suspension

211 SAS	220 AIRmatic
<ol style="list-style-type: none"><li>1. Front air springs w/ integrated dual air chamber and ADS II shock absorber with dampening valves</li><li>2. Rear air springs with remote mounted additional air chamber</li><li>3. Separate rear shock absorber w/ integrated ADS II dampening valves</li><li>4. National version coding stored in CGW (N93)</li><li>5. Re-designed solenoid valve block (Y36/6) with 1 valve</li><li>6. Pressure reservoir (located on right side trunk)</li><li>7. 2 stage Comfort / Sport switch</li></ol>	<ol style="list-style-type: none"><li>1. Front air springs w/single air chamber and ADS II shock absorber with dampening valve</li><li>2. Rear air springs w/single air chamber</li><li>3. Shock absorbers are integrated in rear air springs w/ADS II dampening valves</li><li>4. National version coding stored in EIS (N73)</li><li>5. Solenoid valve block (Y36/6) with 5 valves</li><li>6. Pressure reservoir (located at left front wheel housing under headlamp)</li><li>7. 1 or 2 stage Comfort / Sport switch. (depending on model year)</li></ol>

