



Installation Instructions

Date: April 2007
Order No.: P-I-82.60/309
Supersedes:
Group: 82

**SUBJECT: MODEL 211.0
MODEL YEAR 2004
SATELLITE RADIO INSTALLATION**

We are interested in your comments and/or suggestions regarding these installation instructions—please e-mail them to StarTekInfo@MBUSA.com

⚠ WARNING

Do not disconnect the negative battery cable. Extensive reprogramming requirements are otherwise necessary. Wiring harnesses are therefore electrically active.
Severe vehicle damage, personal injury, or death from electrical shock could result.
Exercise extreme caution while executing these installation instructions. Keep the ignition and radio powered OFF through the final test.

Notes on MOST optical fibers

- Optical fibers damage easily—handle optical fibers with care to prevent cuts, nicks, abrasions, and crushing.
- Optical fiber “ring configurations” must form a closed loop to function (i.e. couple the input of a component with the output of the preceding component).
- Identify MOST optical fibers by their orange, semi-rigid insulation.
- Electromagnetic interference (EMI) from bundled vehicle electrical harnesses does not affect optical fibers.

NOTICE!

Incorrect installation of connectors can result in damaged, bent pins.
Damaged, bent pins will result in component malfunction or failure.
Inspect connectors before and after installation.

This bulletin has been created and maintained in accordance with MBUSA-SLP S423QH001, Document and Data Control, and MBUSA-SLP S424HH001, Control of Quality Records.

A. Installation preparation

1. Read this installation instruction in its entirety before proceeding.
2. Unpack and compare the installation kit contents against the Parts Information list on last page.

B. Drilling the hole in the trunk lid

1. Remove trunk lid paneling (refer to WIS: AR68.30-P-8150T).
2. Mark the interior of the trunk lid at the center of the recessed hole (arrow, Figure 1).
3. Mask the outside with trunk lid in the area of where the hole will be drilled with masking tape (approx 8" X 8" area).
4. From the **bottom** of the trunk lid drill, a 3 mm diameter pilot hole at the mark, then enlarge pilot hole to 6-mm.

 CAUTION
<p>Drilling metal can cause airborne metal debris.</p> <p>Airborne metal debris can cause serious injury to the eyes.</p> <p>Use protective eyewear.</p>

Note:

- **Be careful not to damage the trunk lid. Carefully remove the metal shavings resulting from drilling with a vacuum cleaner or compressed air.**
- **Cover inside of trunk surface to catch metal shavings during drilling. Remove any metal shavings in trunk when finished drilling.**

NOTICE!

Improper or careless drilling can damage metal surfaces.

Paint or body damage to the trunk lid can result.

Exercise care and accuracy when drilling.

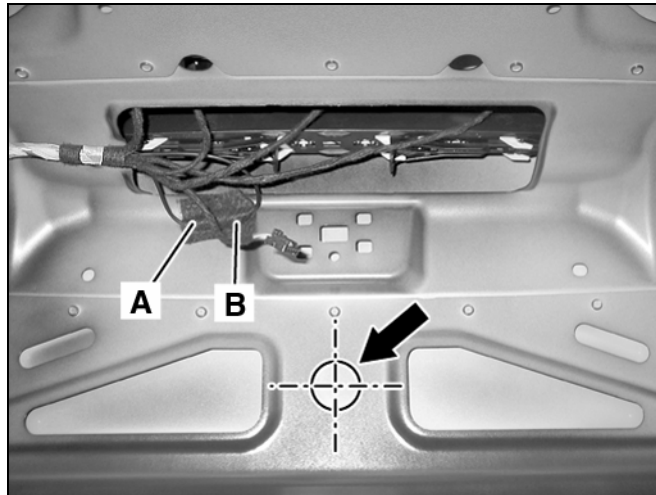

Figure 1

P82.60-4399-01

5. Drill the pilot hole to 20 mm diameter using a

progressive drill bit (local purchase):

- Close trunk lid
- Drill from the **top** side of the trunk lid

NOTICE!

Using a hole saw is not suitable for drilling the hole in the trunk lid.

Using a hole saw will damage the trunk lid.

Do not use a hole saw to drill the trunk lid.

6. Remove burrs.
7. Thoroughly coat the hole edge with primer (part no. A000 986 06 50) and allow to dry.

C. Installing the Satellite Digital Audio Receiver (SDAR) Antenna

1. Affix large plastic washer (10, Figure 2 [part no. A220 827 0611]) to bottom of trunk lid:
 - Remove backing paper (arrow) from washer (10).
 - Insert washer (10) into drilled hole and affix adhesive side of washer to underside of trunk lid.

Note:

Ensure raised surface of washer is raised or flush with surface of trunk lid when installed never recessed.

2. Loosen the T25 Torx screw (arrow, Figure 3) on the SDAR antenna.

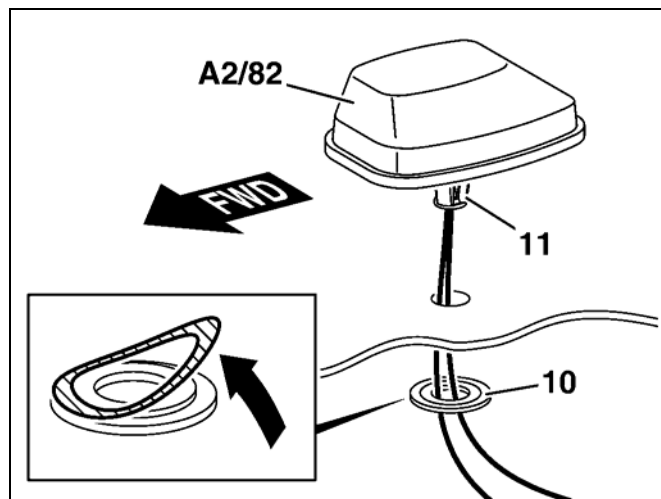

Figure 2

P82.60-4122-01

3. Feed antenna leads coming from the SDAR antenna (A2/82, Figure 2) through the washer (10).
4. Carefully insert the SDAR antenna sleeve (11, Figure 2) into the washer (10) until it snaps into place.

NOTICE!

Applying force to body panels can result in damage.

Excessive force will dent the trunk lid.

Do not use excessive force when inserting antenna sleeve into the 14 mm hole.

5. Align the SDAR antenna straight with the vertical side facing front and the angled side facing rear (A2/82, Figure 2).
6. Apply light downward pressure to the SDAR antenna (A2/82, Figure 2) to ensure the



Figure 3

P82.60-4374-71

gasket fully seals flush against the trunk lid.

NOTICE!

Applying force to body panels can result in damage.

Excessive force will dent the trunk lid.

Do not use excessive force when seating the antenna gasket to the trunk lid.

- Carefully tighten the T25 Torx screw (arrow, Figure 3) in the sleeve of the SDAR antenna.
- Peel back felt tape from underside of trunk lid to locate antenna connectors (A, B, Figure 4) and roll back foam sleeve on connectors.
- Connect the vehicle leads (A, B, Figure 4) to the connectors on the SDAR antenna cables (A, figure 5) and secure connection with plastic clips (attached to vehicle antenna leads). Roll back felt tape over connectors.

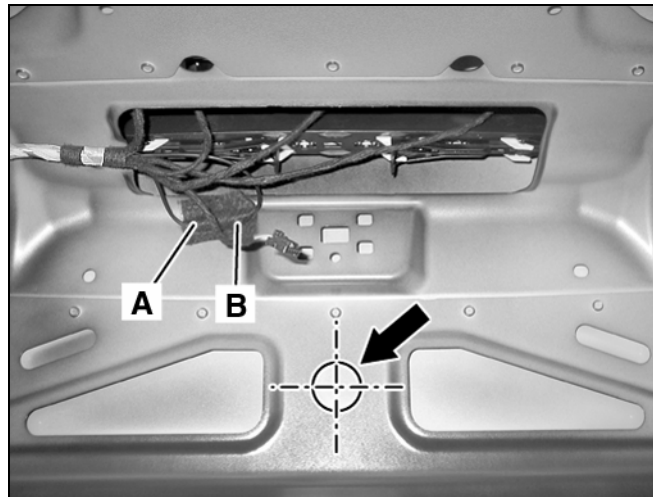

Figure 4

P82.60-4399-01

D. Installing the satellite radio control module

- Remove interior right trunk panel (for vehicles with through loading feature refer to: WIS AR68.30-P-4800TA; for vehicles without through loading feature refer to: WIS AR68.30-P-4800T)
- Mount the SDAR control module (N87/5, Figure 6) to the bracket (5, Figure 6) secure with three M5 hex nuts (arrows) included with installation kit. Be sure to orient the SDAR control module with respect to the bracket as seen in Figure 6.

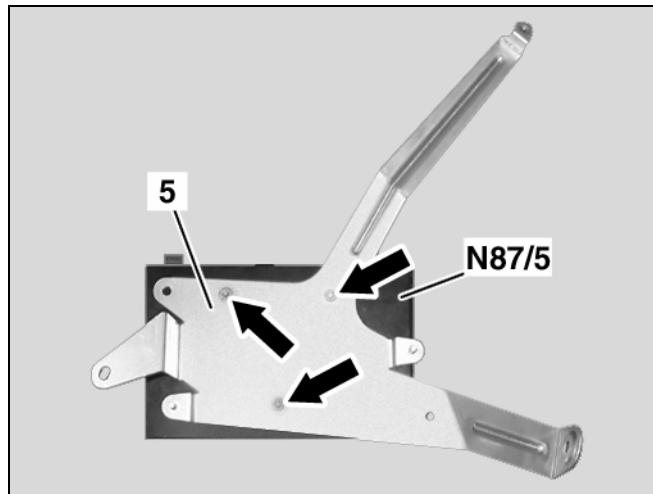

Figure 6

P82.60-4376-71

Note:

- For model 211.076 E55 AMG: install riveted cable tie (arrow, Figure 7) in pre-drilled hole on bracket (A) and place felt tape (B) on corresponding side of bracket assembly.
- If vehicle is equipped with level control proceed to step 3, if not equipped proceed to step 4.

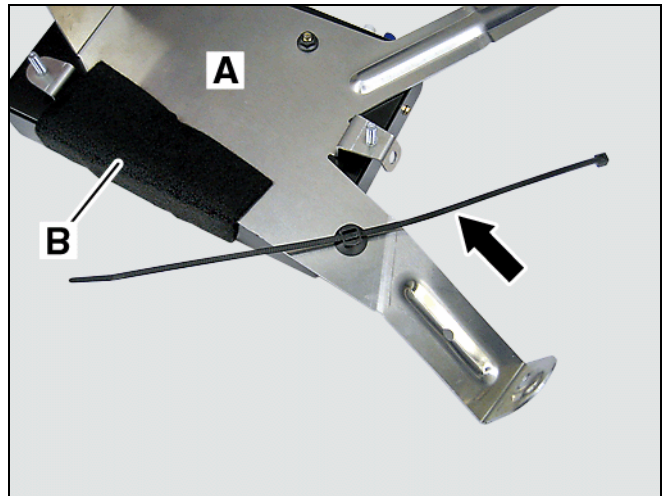

Figure 7

P82.60-4623-71

3. Remove 4 bolts (arrows, Figure 8 [top bolt not shown]) securing air reservoir bracket assembly (A) to vehicle, then reposition air reservoir tank to allow access to right rear side of trunk.

Note:

Do not remove air line (F) from tank.

4. Remove cable tie holder from lower mounting stud (D, Figure 10), next remove nut (arrow, Figure 10) from upper stud (securing ground wire to vehicle body).
5. Secure satellite control module bracket (E, Figure 8) assembly to vehicle:

- Reuse (previously removed) nut (B, Figure 8) to secure bracket to upper stud.

Note: Ensure vehicle ground wire is re-secured to upper stud.

- Use plastic nut (C, Figure 8) provided in installation kit to secure bracket to lower mounting stud.
- Use torx bolt (D, Figure 8) provided in installation kit to secure center bracket support arm to vehicle body.

Note: (model 211.076):

- Secure fuel pump relay harness (A, Figure 9) to SDAR bracket with riveted cable tie (arrow).
- Ensure relay harness is not touching SDAR bracket.

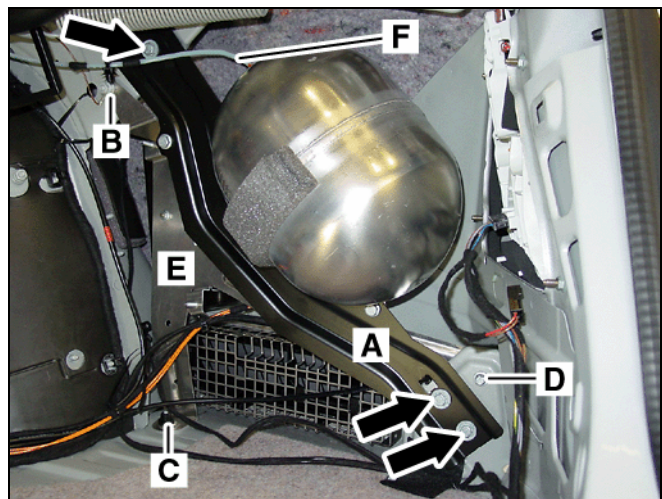

Figure 8

P82.60-4377-71

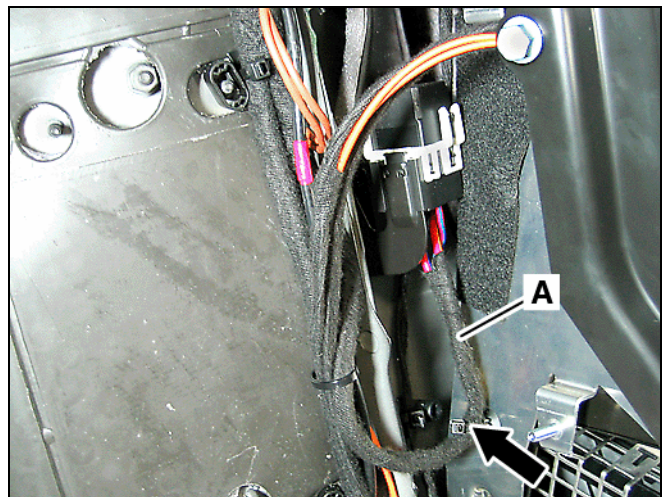

Figure 9

P82.60-4624-71

6. Locate antenna connectors (A, B, Figure 10) and power supply/MOST connector (1) taped to vehicle harness and roll back foam covering to expose antenna connectors.

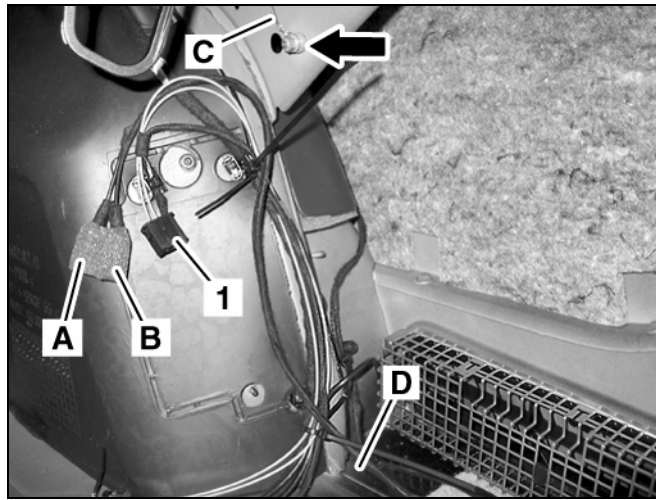

Figure 10

P82.60-4378-71

7. Connect power supply connector (A, Figure 11) and antenna connectors (B) to satellite control module (N87/5).

Note:

Secure wires with cable ties.

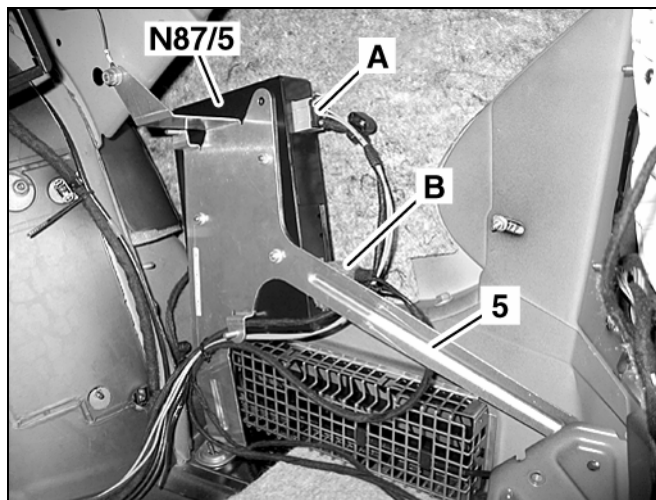

Figure 11

P82.60-4379-01

E. Install fiber optic cable and configure MOST ring

NOTICE!

Improper handling of optical fibers can damage the fibers.

Damaged optical fibers can cause component malfunction.

Handle optical fibers with care to prevent cuts, nicks, abrasions, and crushing.

1. Install fiber optic cable into MOST ring (arrow, Figure 12) as indicated in diagram on the next page (please refer to note below for information on identifying cable connections in relation to component position):

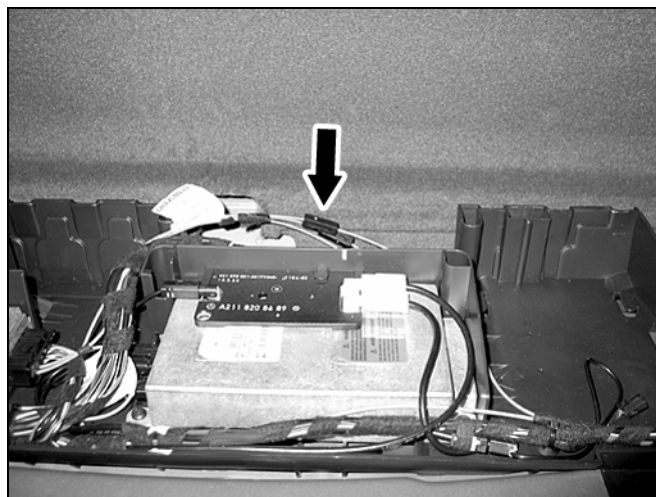

Figure 12

P82.60-4381-01

Note:

MOST cables are not clearly marked with the component that they are connected to. After disassembling the coupling (arrows Figure 13), the most cable connected to the previous component can be determined by turning the key to position 15R. This will cause the ring to wake-up. **The cable that transmits red light is connected to the previous component, the cable without light is connected to the next component.** Use this in configuring the ring.

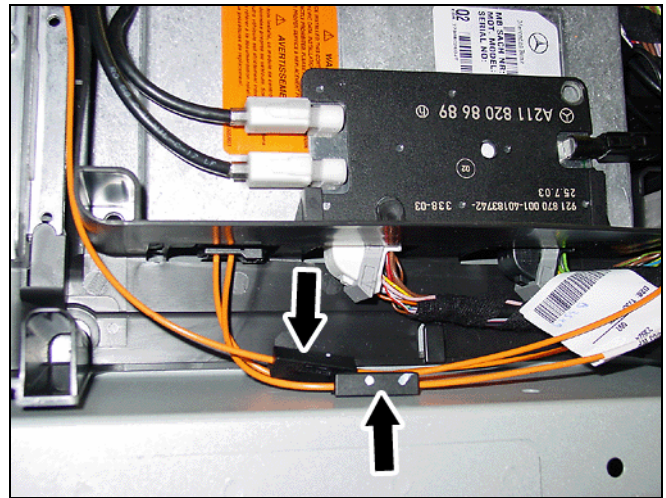

Figure 13

P82.60-4380-71

Most Ring Configuration

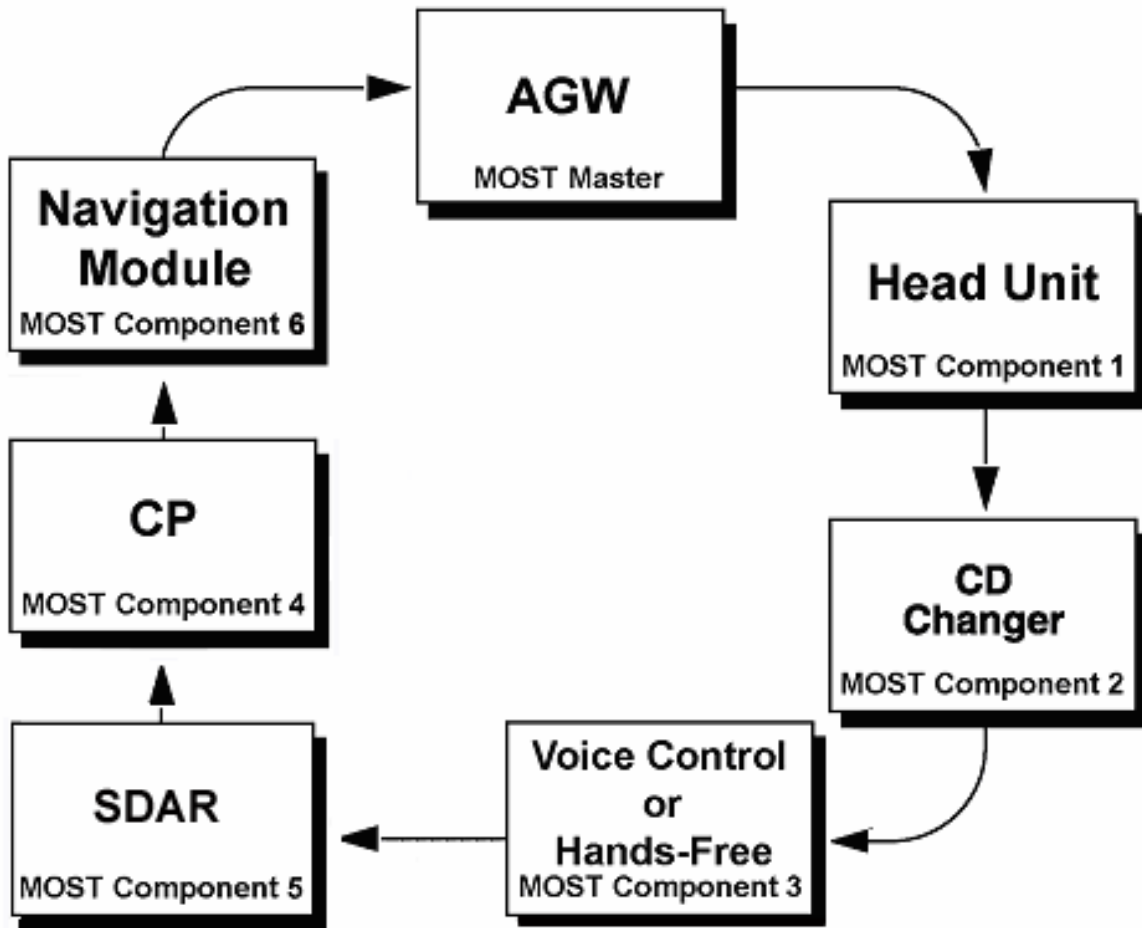

Figure 14

DWS-1

2. Carefully route fiber optic wires as shown (arrows, Figure 15) and secure with cable ties.

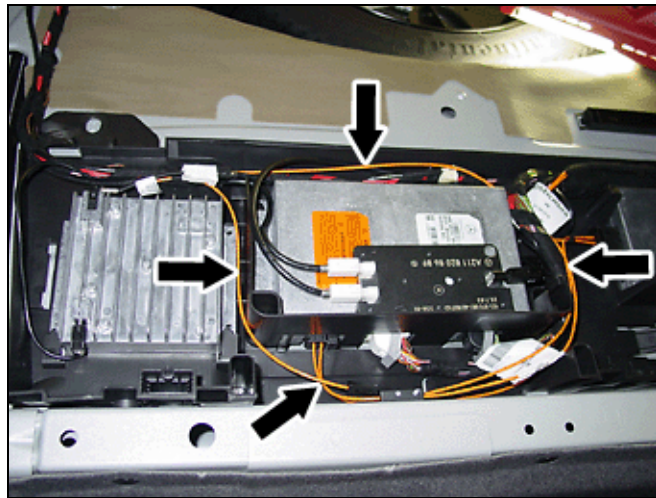

Figure 15

P82.60-4382-71

F. Perform version coding

1. Connect Star Diagnosis to the vehicle.
2. Set the MOST ring configuration to match the diagram on page 7 by using the path: Control Units/Information and communication/Audio, video, navigation and telematics/AGW – Audio gateway/Retrofitting of MOST components (final screen display: “Retrofitting of MOST components” should indicate “Coding has been successfully completed”).

Note: The diagram on page 7 is an example of a MOST ring configuration including all components. Some installations will not include all the components shown in the example. If a component is not present, connect the preceding component to the component following the one not present.

NOTICE!

Match the MOST ring configuration to Figure 14.

Failure to have the configuration match Figure 14 will result in erroneous system operation and/or intermittent malfunctioning of some or all components in the ring.

Do not alter the configuration in Figure 14 to match the vehicle configuration.

3. Check the DTC memory of all installed components and the head unit. Any present DTC(s) should be investigated and the source identified. Once identified, the source of the DTC(s) should be corrected and the DTC memory cleared.

Note: Powering up the newly installed system prior to the above described version coding will set MOST ring configuration errors. These errors may be ignored during the initial DTC check. If, after clearing the DTC(s), they return in the next step, a configuration error is present and must be located and corrected.

4. Confirm that no new DTC(s) have been set in the MOST system group.

G. Final assembly and function testing

1. Verify proper Satellite Radio operation per the following checklist
 - Audio is functional (Radio and CD)
 - Satellite Radio display is present on Head Unit and Instrument Cluster
 - Sirius preview message is heard when Satellite function is selected (Note: Vehicle must be in an area which permits reception)
2. Reassemble vehicle in reverse order.

Parts Information

Qty.	Part Name	Part Number/Exchange
1	SDAR Installation kit, E-Class Sedan (211.0)	B6 783 0002
1	Receiver	B6 783 0012
1	Bracket, Receiver	B6 783 0017
1	Antenna	B6 783 0014
3	Nut, M5X8	N913 023 005 002
1	Screw, M6	N910 143 006 000
1	Nut, plastic	A003 990 0251
1	Right trunk panel (for models without air suspension)	Determine for specific vehicle equipment using EPC

Parts Information

Qty.	Part Name	Part Number/Exchange
1	Cable (loom) tie	A005 997 62 90

Note:

This installation can not be claimed under warranty.