

Service Campaign Bulletin



Mercedes-Benz

Campaign No. 2019080019, November 2019

TO: ALL MERCEDES-BENZ CENTERS

SUBJECT: **Various Models**
Model Years 2012-2017

Replace Steering Gear Bolts

Mercedes-Benz AG ("MBAG"), the manufacturer of Mercedes-Benz vehicles, has determined that on certain Model Year ("MY") 12-17 C-Class, CLS-Class, E-Class, GL-Class, GLC-Class, GLE-Class, GLK-Class, GLS-Class, M-Class, S-Class (205, 218, 207, 212, 213, 166, 253, 292, 204, 217, 222 platforms) vehicles, the aluminum bolts of the steering gear housing cover and the aluminum bolts on the power steering rack may corrode over time due to moisture intrusion in combination with aggressive road salt. The corrosion, in combination with driving loads could result in the fracturing of the corroded bolt(s). If all the bolts were to fracture, this could lead to a separation of the power steering unit from the steering rack and could result in power steering failure. An authorized Mercedes-Benz dealer will replace the aluminum bolts of the steering gear housing cover and the aluminum bolts on the power steering rack and seal them, or replace the power steering rack if necessary.

Prior to performing this Service Campaign:

- Please check VMI to determine if the vehicle is involved in the Campaign and if it has been previously repaired. Always Check VMI for any open campaigns, and perform accordingly.
- Please review the entire Service Campaign bulletin and follow the repair procedure exactly as described.
- **Take into account the 3 different work procedures based on the different models**
- **Do not pre-order electric power steering racks for this topic until initial repair procedure is performed.**

Approximately 398,527 vehicles are affected.

Order No. P-SC-2019080019

This bulletin has been created and maintained in accordance with MBUSA-SLP S423QH001, Document and Data Control, and MBUSA-SLP S424HH001, Control of Quality Records.

Service Campaign Bulletin

Service Campaign Bulletin

Service Campaign Bulletin

Service Campaign Bulletin

Service Campaign Bulletin

- i** Important: Take into account the different work procedures.
- i** Important: Take into account the different parts kits in the parts table.

i If the steering has to be replaced, the steering must be returned with all (including any broken off) parts in the original packaging. All parts will be individually checked and analyzed with regard to the cause of the damage.

Work procedure

For models 204, 207, 212, 217, 218, and 222

1. Remove center section of lower engine compartment lining.
2. Remove mounting plate (A, Figure 1) for steering gear.
 - i** For basic data, see **AR46.20P-0600EL**.
 - i** For basic data, see **AR46.20-P-0600LF**.



Figure 1

3. Slightly release steering gear and secure against falling down with transmission jack.



Figure 2

4. Remove screws (B and C, Figure 2), making **absolutely sure** to do so **individually and one after the other**, replace with new steel screws and tighten with the specified torque incl. tightening angle.
 - i** The procedure must be completed so that the power-pack does not twist away from its set position thus resulting in consequential damage.
 - Nm** Power-pack screw on steering gear: **5 Nm and 90°** tightening angle.
 - i** If a **screw** should **break off** or have already broken off, **replace the electric power steering rack.**
 - i** For basic data, **see AR46.20-P-0600EL and AR46.20-P-0600EF.**
 - i** If the steering has to be replaced, the steering must be returned with all (including any broken off) parts in the original packaging. All steering racks will be individually checked and analyzed with regard to the cause of the damage.
5. After replacing the screws, apply a generous coat of wax to the area (**D**, Figure 3) around the screw heads, screw ends, and the gap between the power-pack and the steering.
 - i** Wax gap between power-pack and steering **all-round.**

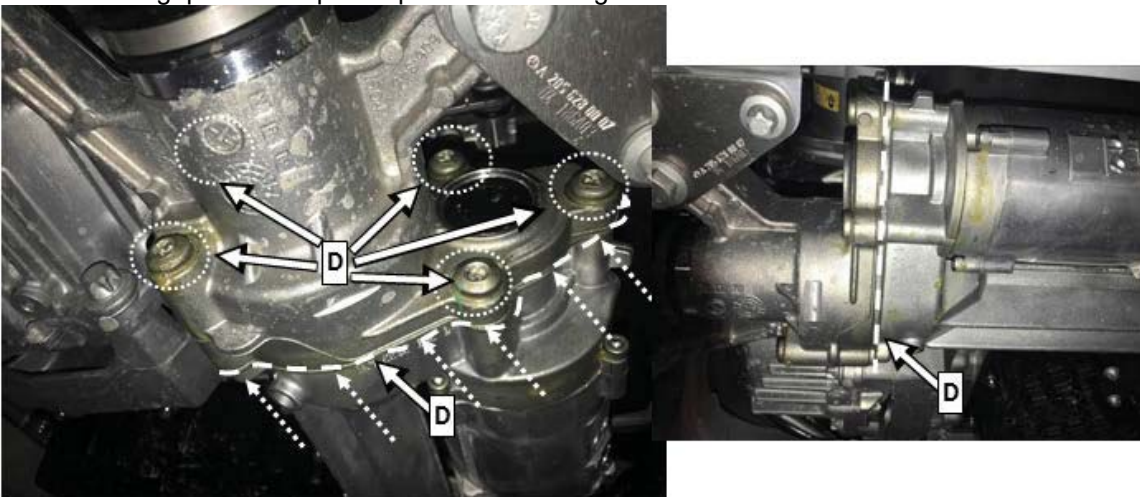

Figure 3

6. Assemble in reverse order.
7. Perform wheel alignment check and carry out toe adjustment.
8. Reset the learned values for the electric power steering with XENTRY Diagnosis.

i To do this, select menu item "**Quick test view – N68 Electric power steering (ES) – Adaptations – Teach-in processes – Reset learned values**".

i Then follow the user guidance in XENTRY Diagnosis.

Work procedure

For models 205, 213, 238, and 253

1. Remove center section of lower engine compartment lining.
2. Remove screws (B and C, Figure 2), making **absolutely sure** to do so **individually and one after the other**, replace with new steel screws and tighten with the specified torque incl. tightening angle.
 - i** The procedure must be complied with so that the power-pack does not twist away from its set position thus resulting in consequential damage.
 - i** For models 205, 213, 238, and 253, the steering **does not have** to be released from the front axle carrier.
 - Nm** Power-pack screw on steering gear: **5 Nm and 90°** tightening angle.
 - i** If a **screw** should **break off** or have already broken off, **replace the electric power steering rack**.
 - i** For basic data, see **AR46.20-P-0600LW** and **AR46.20-P-0600LWO**.
 - i** If the steering has to be replaced, the steering must be returned with all (including any broken off) parts in the original packaging. All steering racks will be individually checked and analyzed with regard to the cause of the damage.



Figure 4

3. After replacing the screws, apply a generous coat of wax to the area (**D, Figure 3**) around the threaded connections and around the gap between the power-pack and the steering.
 - i** Wax gap between power-pack and steering **all-round**.
4. Assemble in reverse order.

Work procedure

For models 166 and 292

1. Remove center section of lower engine compartment lining.
2. Remove screws (E, Figure 5) connecting the front axle differential to the front axle carrier.
 - i** Front axle differential remains lying in front axle carrier. It is only slightly lowered.
 - i** **No further** threaded connections are released at front axle differential.
 - i** For basic data, see **AR33.30-P-0525GQ**



Figure 5

3. Unscrew steering from front axle carrier and tie rods at the steering knuckles (**F**, **Figure 6**).

- i** Steering coupling to steering column is **NOT** released.
- i** For basic data, see **AR46.20-P-0600GQ** and **AR46.40-P-0200EW**
- i** Additional threaded connections do not have to be released.
- i** Remove retaining plates (**G**, **Figure 6**).

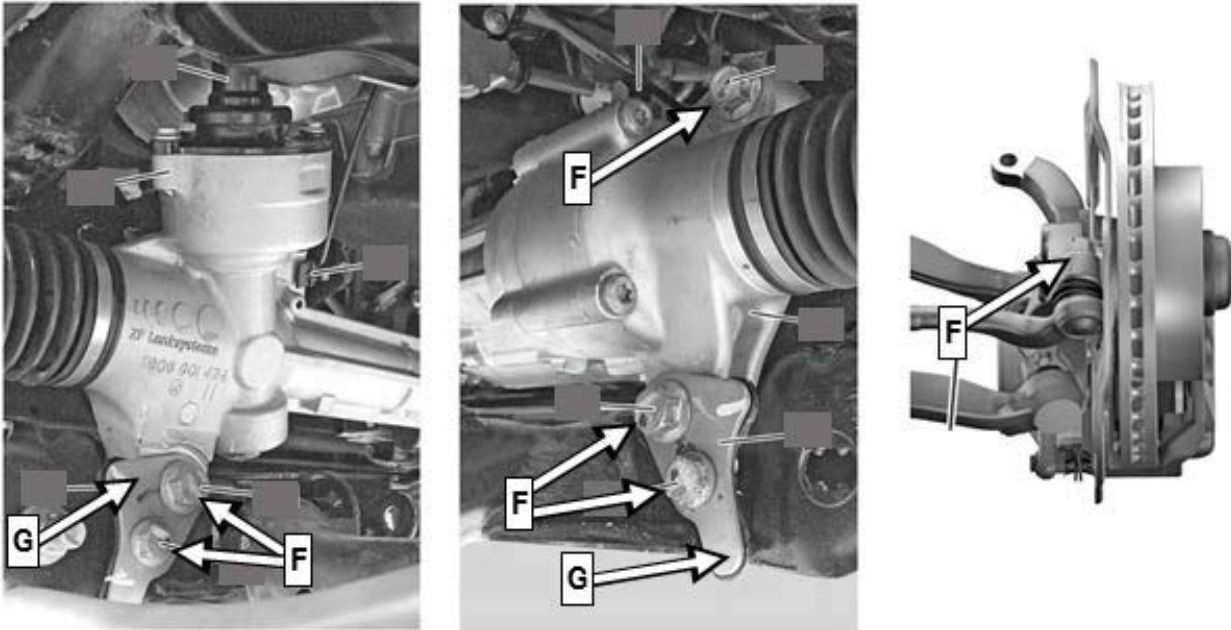

Figure 6

4. For vehicles **with code 468 (Active Curve System)**, unscrew the hydraulics block (**Figure 7**) and slightly press downwards with lines connected.



Figure 7

5. Slightly lift steering on left and right and move towards rear in front axle carrier so that the screws (**B and C**, **Figure 8**) are accessible.

i Keep the steering pressed towards the rear with the aid of a helper as shown (**Figure 9**).

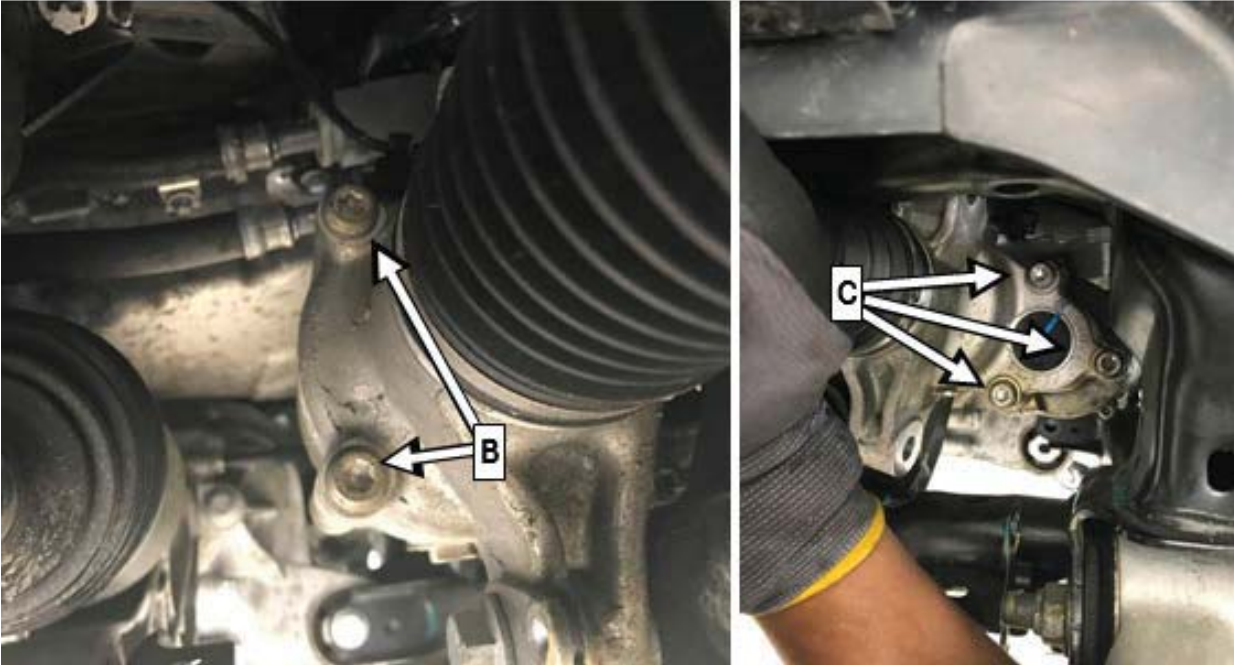

Figure 8



Figure 9

6. Remove screws (**B and C, Figure 8**), making **absolutely sure** to do so **individually and one after the other**, replace with new steel screws and tighten with the specified torque incl. tightening angle.
- i** The procedure must be complied with so that the power-pack does not twist away from its set position thus resulting in consequential damage.
 - i** **Important:** Take into account the different screw lengths of screws B and C in models 166 and 292!
 - Nm** Power-pack screw on steering gear: **5 Nm and 90°** tightening angle.
 - i** If a **screw** should **break off** or have already broken off, **replace the electric steering rack**.
 - i** For basic data, **see AR46.20-P-0600GQ and AR46.40-P-0200EW**.
 - i** If the steering has to be replaced, the steering must be returned with all (including any broken off) parts in the original packaging. All steering racks will be individually checked and analyzed with regard to the cause of the damage.
7. After replacing the screws, apply a generous coat of wax to the area (**D, Figure 3**) around the threaded connections and around the gap between the power-pack and the steering.
- i** Wax gap between power-pack and steering **all-round**.
8. Assemble in reverse order.
9. Perform wheel alignment check and carry out toe adjustment.
10. Reset the learned values for the electric power steering with XENTRY Diagnosis.
- i** To do this, select menu item "**Quick test view – N68 Electric power steering (ES) – Adaptations – Teach-in processes – Reset learned values**".
 - i** Then follow the user guidance in XENTRY Diagnosis.

Primary Parts Information

Qty.	Part Name	Part Number	Estimated Replacement Rate
1(As required)	Screw set (204, 207, 212, 217, 218, and 222)	A 212 460 07 01	100%
1(As required)	Screw set (205, 213, 238, and 253)	A 205 460 86 02	100%
1(As required)	Screw set (166 and 292)	A 166 460 18 01	100%
0.1*	Wax	A 000 986 72 70 10	100%
1(As required)**	Electric power steering	**	0.5%

* One wax container is enough for approx. 10 vehicles.

** Determine the correct electric power steering rack in XPPI using equipment code. Do not pre-order parts until bolt replacement is performed.

- i** **Note:** Small parts such as screws, stop nuts, sealing rings, cable ties, fluids, sealants, etc. are not listed in the parts list. The required small parts (per WIS) are taken into account in the budgeting and can be claimed.

Warranty Information

Operation: Connect/disconnect battery charger (02-5058)
 Star Diagnosis System (SDS), Connect/disconnect (02-4762)
 Perform wheel alignment check and toe adjustment (02-9785)*
 Replace 5 screws on steering gear, apply wax (02-2930)
 Extra work for: Replace screws on steering gear, with damaged screw (02-2938)
 Extra work for: Replace screws on steering gear, apply wax for veh. with code 468 , only **models 166 and 292**(02-2931)
 Extra work for: Replace screws on steering gear, apply wax for veh. with damaged screw and code 468, only **models 166 and 292** (02-2939)
Includes: Additional operations for: Replace power steering in case of active roll stabilization
 Extra work for: Replace screws on steering gear, apply wax for veh. with damaged screw and **code 489**, only **models 166 and 292** (02-2940)
Includes: Additional operations for: Replace power steering system in case of AIRMATIC

Damage Code	Operation Number	Labor Time (hrs.)
46 940 11 7	02-5058	0.1
	02-4762	0.1
	02-9785*	0.9
	02-2930 (204, 207, 212, 217, 218, and 222)	1.0
	02-2930 (205, 213, 238, and 253)	0.6
	02-2930 (166 and 292)	2.2
	02-2938 (204, 205, 207, 212, 218, and 253)	1.1
	02-2938 (217 and 222)	1.2
	02-2938 (213 and 238)	1.3
	02-2938 (166 and 292)	4.2
	02-2931 (166 and 292)	0.1
	02-2939 (166 and 292)	0.9
	02-2940 (166 and 292)	0.5

*Excludes (205, 213, 238, and 253) unless replacement of steering gear is required.

i **Note:** Only wheel alignment check and toe adjustment are covered within this campaign. All other alignment adjustments needed are considered pre-existing and not included. Pre-existing conditions are to be evaluated by the dealer and managed outside of the campaign.

i **Note:** Operation times are subject to change