

Engine 157, 278 in model 212, 218

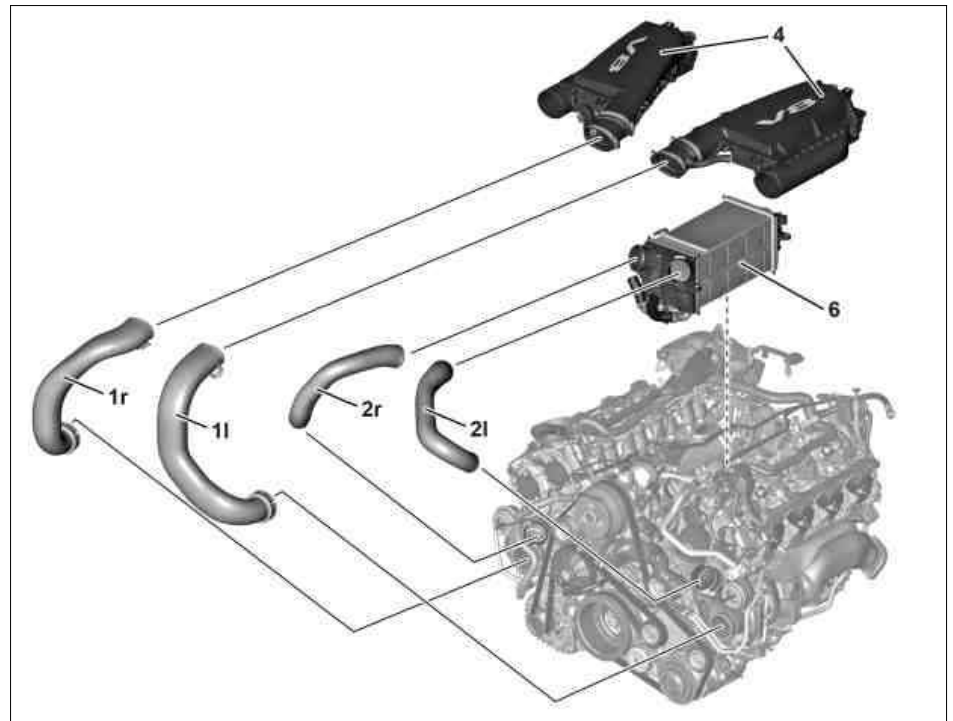





Engine 278 in model 207

- 1l Upper charge air duct on the left
 1r Upper charge air duct on the right
 2l Lower charge air duct on the left
 2r Lower charge air duct on the right
 4 Air cleaner housing
 6 Charge air cooler



P09.41-2593-06

☒ ☒	Remove/install		
	Risk of injury caused by fingers being jammed or pinched when removing, installing or aligning hoods, doors, trunk lid/rear-end door or sliding roof.	No parts of the body or limbs should be within the operating area when the components are moving.	AS00.00-Z-0011-01A
1	Remove engine covers		
2	Loosen clamp between upper charge air duct (1l, 1r) and air filter housing (4)	<input type="checkbox"/> The boot between the upper charge air duct (1l, 1r) and air filter housing (4) remains on the air filter housing (4).	
3	Loosen clamp between upper charge air duct (1l, 1r) and turbocharger	<input type="checkbox"/> The boot between turbocharger and upper charge air duct (1l, 1r) remains on the upper charge air duct (1l, 1r).	
4	Remove screw/bolt for upper charge air duct (1l, 1r) on cylinder head cover	<input checked="" type="checkbox"/> Bolt, charge air manifold to front cover/oil filter housing/cylinder head/ cylinder head cover	*BA09.40-P-1008-01R
5	Remove upper charge air duct (1l, 1r)	<input type="checkbox"/> Plug openings. <input checked="" type="checkbox"/> Set of protective caps	*001589029100
6	Remove air filter housing (4)		
7	Detach engine oil cooling oil lines from oil filter housing and bracket on engine and lay to the side outside the working area	Vehicles with code (139) Measures for engine cooling M157/M278 <input type="checkbox"/> Seal openings using stop plugs. <input type="checkbox"/> Installation: Replace sealing rings and clean connection area of the oil lines. <input checked="" type="checkbox"/> Record plug	*129589009100
8	Loosen clamp between lower charge air duct (2l, 2r) and charge air cooler (6)	<input type="checkbox"/> The boot between lower charge air duct (2l, 2r) and charge air cooler (6) remains on the charge air cooler (6).	
9	Loosen clamp between lower charge air duct (2l, 2r) and turbocharger	<input type="checkbox"/> The boot between lower charge air duct (2l, 2r) and turbocharger remains on the turbocharger.	

10	Remove screw/bolts for right lower charge air duct (2r) from cylinder head	When removing the right lower charge air duct (2r)  Bolt, charge air manifold to front cover/oil filter housing/cylinder head/ cylinder head cover	*BA09.40-P-1008-01R
11	Remove screw/bolts for lower charge air duct on the left (2l) from cylinder head and oil filter housing	When removing the left lower charge air duct (2r)  Bolt, charge air manifold to front cover/oil filter housing/cylinder head/ cylinder head cover	*BA09.40-P-1008-01R
12	Remove lower charge air duct (2l, 2r)	 Plug openings.  Set of protective caps	*001589029100
	Check		
13	Check boot and rubber seal for cracks or damage and replace if necessary		
14	Check clamps for damage and replace as necessary		
15	Install in the reverse order		
	Check		
16	Risk of accident from vehicle starting off by itself when engine running. Risk of injury (bruises and burns) resulting from working on the engine while it is being started or when it is running. Carry out an engine test run, checking the engine for proper operation and leaktightness	Secure vehicle to prevent it from starting off by itself. Wear closed and snug-fitting work clothes. Do not touch hot or rotating parts.	AS00.00-Z-0005-01A

 Turbocharger

Number	Designation	Engine 157	Engine 278
BA09.40-P-1008-01R	Bolt, charge air manifold to front cover/oil filter housing/cylinder head/ Nm cylinder head cover	9	9

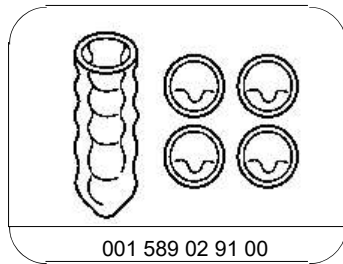

001 589 02 91 00

Set of protective caps

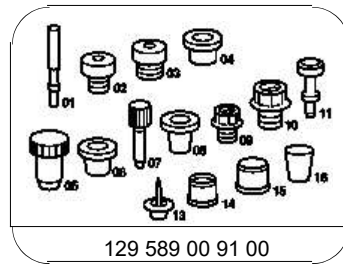

129 589 00 91 00

Record plug