

Model 212, 218
except code M005 (4MATIC)

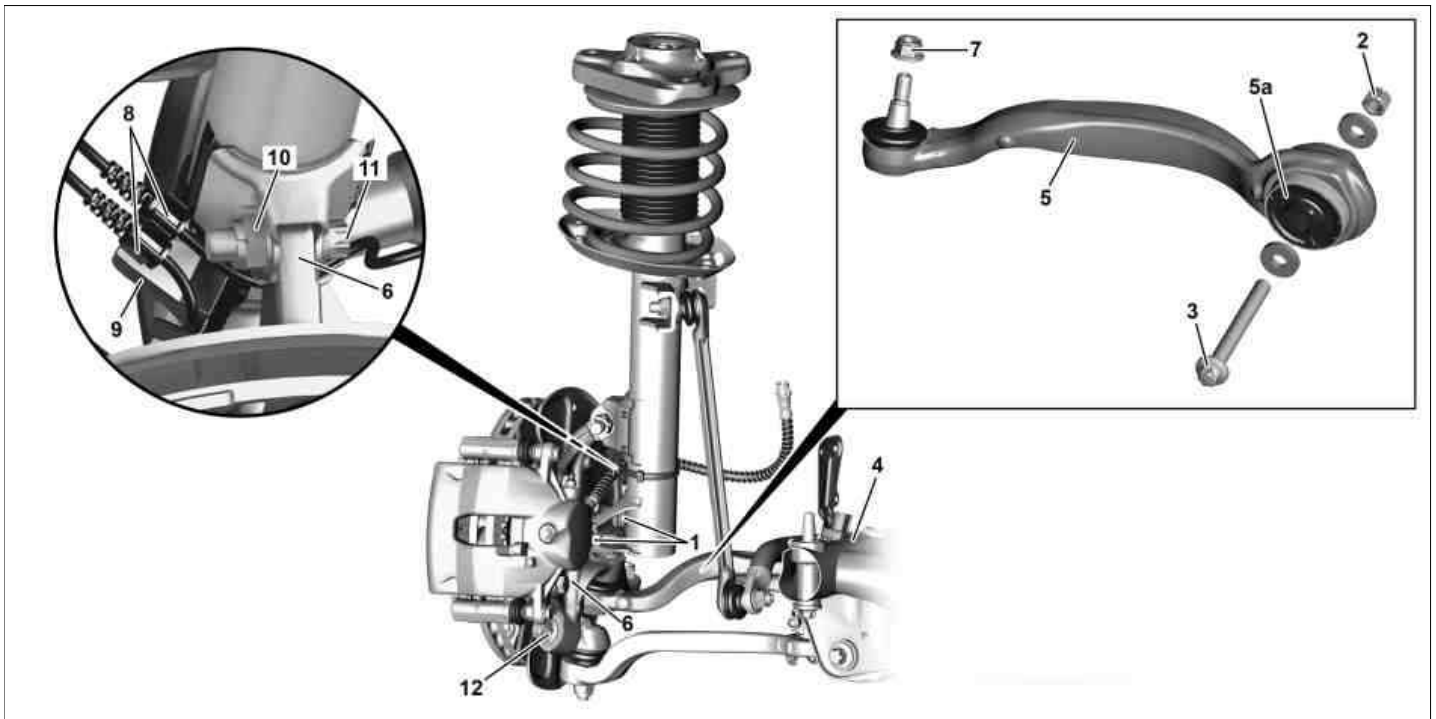

P33.15-2124-09

Shown on vehicle except CODE 460 (Canada version) and except CODE 494 (USA version)





- | | | |
|----------------------|----------------------|----------|
| 1 Bolts | 5a Elastomer bearing | 10 Nut |
| 2 Nut | 6 Steering knuckle | 11 Screw |
| 3 Screw | 7 Nut | 12 Nut |
| 4 Front axle carrier | 8 Electrical lines | |
| 5 Strut rod | 9 Line bracket | |

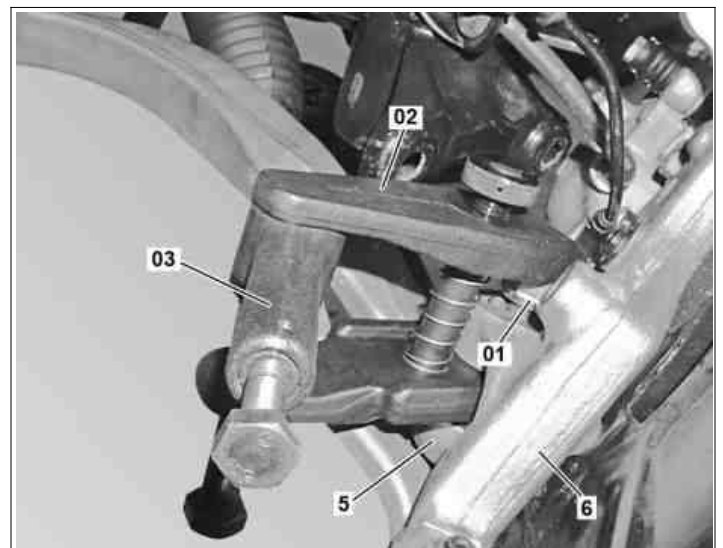

















Shown on vehicle except CODE 460 (Canada version) and except CODE 494 (USA version)









- | |
|--------------------|
| 01 Thrust piece |
| 02 Puller |
| 03 Press |
| 5 Strut rod |
| 6 Steering knuckle |



P33.15-2125-11

	Risk of death caused by vehicle slipping or toppling off of the lifting platform.	Align vehicle between vehicle lift columns and position the four support plates at the vehicle lift support points specified by the vehicle manufacturer.	AS00.00-Z-0010-01A
	Notes on self-locking nuts and bolts		AH00.00-N-0001-01A
	Notes on repair work on suspension components		AH00.00-P-0100-01A
	Remove/install		
1	Secure vehicle on vehicle lift		AR00.60-P-0100EWS
2	Remove left or right front wheel		AP40.10-P-4050EW
			
3.1	Remove center and rear engine compartment paneling	Model 212 with engine 156, 157, 271, 272, 273, 274, 276, 278 except code M005 (4MATIC) Model 218 with engine 157, 274, 276, 278 except code M005 (4MATIC)	AR61.20-P-1105EW
3.2	Remove center and rear bottom part of noise encapsulation	Model 212 with engine 642, 651 except code M005 (4MATIC) Model 218 with engine 642, 651 except code M005 (4MATIC)	AR94.30-P-5300EW
4	Unclip bracket of linkage for left front level sensor from left cross strut	Model 212 with code 488 (Steel/air suspension) except code M005 (4MATIC) Model 212 with code 489 (AIRMATIC) except code M005 (4MATIC) Model 212 with code 615 (Bi-xenon headlamps with active light function) except code M005 (4MATIC) Model 212 with code 621 (Intelligent Light System (left-hand traffic)) except code M005 (4MATIC) Model 212 with code 622 (Intelligent Light System) except code M005 (4MATIC) Model 212 with code 640 (SAE dynamic LED headlamps, right-hand traffic) except code M005 (4MATIC) Model 212 with code 641 (Dynamic LED headlamps, left-hand traffic) except code M005 (4MATIC) Model 212 with code 642 (Dynamic LED headlamps, right-hand traffic) except code M005 (4MATIC) Model 218 except code M005 (4MATIC) When removing the left strut rod (5).  Do not unclip linkage of left front level sensor from bracket. Otherwise, the linkage of the left front level sensor may be damaged.	
5	Unclip bracket of linkage for left front level sensor from right cross strut	Model 212, 218 with code 488 (Steel/air suspension) except code M005 (4MATIC) Model 212, 218 with code 489 (AIRMATIC) except code M005 (4MATIC) When removing the right strut rod (5).  Do not unclip linkage of right front level sensor from bracket. Otherwise, the linkage of the right front level sensor may be damaged.	
6	Unhook electrical lines (8) from left or right line bracket (9)		

7	Open cable tie of line bracket (9) and detach from damper	 Installation: Replace cable tie.	
8	Remove bolts (1) from left or right steering knuckle (6)	 MODEL 212, 218 except CODE M005 (4MATIC) Bolt, suspension strut to steering knuckle at bottom	*BA32.25-P-1002-04M
9 WS	Prop up left or right front-axle half 000 588 11 62 00 Major assembly mount		WS01.00-P-0092B
10	Remove left or right supporting strut	Model 212.0 as of model year 2015 with code 460 (Canada version) except code M005 (4MATIC) Model 212.0 as of model year 2015 with code 494 (US version) except code M005 (4MATIC)	AR33.25-P-0001EW
11	Unscrew nut (10) from left or right steering knuckle (6) and remove bolt (11)	 Installation: Replace bolt (11).  MODEL 212, 218 Bolt, suspension strut to steering knuckle at top	*BA32.25-P-1001-04M
12	Fold down steering knuckle (6) and place line bracket (9) to one side	 Do not pull on brake hose when folding down. Otherwise the brake hose will be damaged.	
13	Unscrew nut (7)	 MODEL 218 except CODE M005 (4MATIC) Self-locking nut, strut rod to steering knuckle  MODEL 212 except CODE M005 (4MATIC) Locknut, strut rod to steering knuckle	*BA33.20-P-1004-01Q *BA33.20-P-1004-01O
14	Detach strut rod (5) with thrust piece (01), puller (02) and press (03) from steering knuckle (6)	 Installation: The grease in the radial groove must not be removed. There must be no grease on the cone and on the thread.  Thrust piece  Puller  Press	*171589003400 *221589003300 *163589034300
15	Secure steering knuckle (6), using previously-removed bolt (11), onto suspension strut		
16	Unscrew nut (12) from steering knuckle (6)	 MODEL 212 except CODE M005 (4MATIC) Nut, upper ball joint to steering knuckle  MODEL 218 except CODE M005 (4MATIC) Nut, upper ball joint to steering knuckle	*BA33.20-P-1008-01O *BA33.20-P-1008-01Q
17	Press off upper ball joint from steering knuckle (6)		AR33.20-P-0427EW
18	Unscrew nut from cross strut mounting on front axle carrier (4) and remove bolt from front axle carrier (4)	 Always counterhold bolt when releasing the nut to ensure that the bolt does not turn too. Otherwise, on cross struts with an installed repair kit, the lock tabs for the camber adjustment in the elastomer bearing may be sheared off.  Installation: Tighten nut of bolt far enough so that the elastomer bearing can still turn when rocking vehicle to settle suspension. Do not tighten nut until in the ready to drive condition.  MODEL 218 except CODE M005 (4MATIC) Screw/bolt, cross strut to front axle carrier  MODEL 218 except CODE M005 (4MATIC) Self-locking nut (repair kit), cross strut to front axle carrier  MODEL 212 except CODE M005 (4MATIC) Bolt, cross strut to integral carrier  MODEL 212 except CODE M005 (4MATIC) Locknut (repair kit), cross strut to integral carrier	*BA33.20-P-1005-01Q *BA33.20-P-1006-01Q *BA33.20-P-1005-01O *BA33.20-P-1006-01O
19	Remove cross strut		

20	Unscrew nut (2) and pull bolt (3) out of front axle carrier (4)	 Always counterhold bolt (3) when releasing the nut (2) so that the bolt (3) is unable to turn. Otherwise, on strut rods (5) with an installed repair kit, the lock tabs for the caster adjustment in the elastomer bearing (5a) may be sheared off.  Installation: Tighten nut (2) of bolt (3) far enough so that the elastomer bearing (5a) can still turn when rocking vehicle to settle suspension. Tighten nut (2) only after vehicle in ready-to-drive condition.  MODEL 212 except CODE M005 (4MATIC) Bolt, strut rod to integral support  MODEL 212 except CODE M005 (4MATIC) Locknut (repair kit), strut rod to integral carrier  MODEL 218 except CODE M005 (4MATIC) Bolt, strut rod to front axle carrier  MODEL 218 except CODE M005 (4MATIC) Self-locking nut (repair kit), strut rod to front axle carrier	*BA33.20-P-1002-01O *BA33.20-P-1003-01O *BA33.20-P-1002-01Q *BA33.20-P-1003-01Q
21	Remove strut rod (5)		
	Check		
22	Check dust boot and ball joint of strut rod (5) for damage	If damage is present: ↓ Replace strut rod (5).	
23	Check elastomer bearing (5a) of strut rod (5) for damage	If damage is present: ↓ Replace elastomer bearing (5a) of strut rod (5).  Extraction and installation tool	AR33.15-P-0160-02EW *212589004300
24	Install in the reverse order		
25	Perform wheel alignment check		AR40.20-P-0200EW

 Suspension struts

Number	Designation			MODEL 212.00/02/03/04/05/0 61/065/072/073/095/0 98/13/14/15/162/165/ 19/20/22/23/24/25/26 1/265/272/273/298 except CODE 489, MODEL 212.074/075/077/274/ 275/277 except CODE 488/489	MODEL 212.00/02/03/04/05/0 61/065/072/073/095/ 098/13/14/15/162/16 5/19/20/22/23/24/25/ 261/265/272/273/298 with CODE 489, MODEL 212.074/075/077/274 /275/277 with CODE 489, except CODE 488	
BA32.25-P-1001-04M	Bolt, suspension strut to steering knuckle at top	M14×45	Stage 1	Nm	100	100
			Stage 2	∠°	90	90

 Suspension struts

Number	Designation			MODEL 212.074/075/077/274/ 275/277 with CODE 488, except CODE 489	MODEL 218.30/32/33/35/361/ 362/365/373/90/92/9 3/95/961/965/973 except CODE 489, MODEL 218.374/375/974/975 except CODE 488/489	
BA32.25-P-1001-04M	Bolt, suspension strut to steering knuckle at top	M14×45	Stage 1	Nm	100	100

		Stage 2	∠°	90	90
--	--	---------	----	----	----

Nm Suspension struts

Number	Designation	MODEL 218.30/32/33/35/361/ 362/365/373/90/92/93 /95/961/965/973 with CODE 489, MODEL 218.374/375/974/975 with CODE 489, except CODE 488	MODEL 218.374/375/974/975 with CODE 488
BA32.25-P-1001-04M	Bolt, suspension strut to steering knuckle at top M14×45	Stage 1 Nm	100
		Stage 2 ∠°	90

Nm Suspension struts

Number	Designation	MODEL 212.00/02/03/04/05/0 61/065/072/073/095/0 98/13/14/15/162/165/ 19/20/22/23/24/25/26 1/265/272/273/298 except CODE 489, MODEL 212.074/075/077/274/ 275/277 except CODE 488/489	MODEL 212.00/02/03/04/05/0 61/065/072/073/095/ 098/13/14/15/162/16 5/19/20/22/23/24/25/ 261/265/272/273/298 with CODE 489, MODEL 212.074/075/077/274 /275/277 with CODE 489, except CODE 488
BA32.25-P-1002-04M	Bolt, suspension strut to steering knuckle at bottom M12×20	Stage 1 Nm	70
		Stage 2	lösen
		Stage 3 Nm	100

Nm Suspension struts

Number	Designation	MODEL 212.074/075/077/274/ 275/277 with CODE 488, except CODE 489	MODEL 218.30/32/33/35/361/ 362/365/373/90/92/9 3/95/961/965/973 except CODE 489, MODEL 218.374/375/974/975 except CODE 488/489
BA32.25-P-1002-04M	Bolt, suspension strut to steering knuckle at bottom M12×20	Stage 1 Nm	70
		Stage 2	lösen
		Stage 3 Nm	100

Nm Suspension struts

Number	Designation	MODEL 218.30/32/33/35/361/ 362/365/373/90/92/93 /95/961/965/973 with CODE 489, MODEL 218.374/375/974/975 with CODE 489, except CODE 488	MODEL 218.374/375/974/975 with CODE 488
BA32.25-P-1002-04M	Bolt, suspension strut to steering knuckle at bottom M12×20	Stage 1 Nm	70
		Stage 2	lösen
		Stage 3 Nm	100

Nm Wheel control, hub

Number	Designation			Model 212 except 4MATIC
BA33.20-P-1002-01O	Bolt, strut rod to integral support	Stage 1	Nm	120
		Stage 2	Δ°	180

Nm Wheel control, hub

Number	Designation			MODEL 218 except 4MATIC
BA33.20-P-1002-01Q	Bolt, strut rod to front axle carrier	Stage 1	Nm	120
		Stage 2	Δ°	180

Nm Wheel control, hub

Number	Designation			Model 212 except 4MATIC
BA33.20-P-1003-01O	Locknut (repair kit), strut M14×1.5×11.9 rod to integral carrier	Stage 1	Nm	100
		Stage 2	Δ°	180

Nm Wheel control, hub

Number	Designation			MODEL 218 except 4MATIC
BA33.20-P-1003-01Q	Self-locking nut (repair kit),Stage 1 strut rod to front axle carrier	M14×120×11.9	Nm	100
		Stage 2	Δ°	180

Nm Wheel control, hub

Number	Designation			Model 212 except 4MATIC
BA33.20-P-1004-01O	Locknut, strut rod to steering knuckle	Stage 1	Nm	50
		Stage 2	Δ°	90

Nm Wheel control, hub

Number	Designation			MODEL 218 except 4MATIC
BA33.20-P-1004-01Q	Self-locking nut, strut rod to steering knuckle	Stage 1	Nm	50
		Stage 2	Δ°	90

Nm Wheel control, hub

Number	Designation			Model 212 except 4MATIC
BA33.20-P-1005-01O	Bolt, cross strut to integral carrier	Stage 1	Nm	120
		Stage 2	Δ°	180

Nm Wheel control, hub

Number	Designation			MODEL 218 except 4MATIC
BA33.20-P-1005-01Q	Screw/bolt, cross strut to front axle carrier	Stage 1	Nm	120
		Stage 2	Δ°	180

Nm Wheel control, hub

Number	Designation			Model 212 except 4MATIC
BA33.20-P-1006-01O	Locknut (repair kit), cross M14×120×11.9 strut to integral carrier	Stage 1	Nm	100
		Stage 2	Δ°	180

Nm Wheel control, hub

Number	Designation			MODEL 218 except 4MATIC
BA33.20-P-1006-01Q	Self-locking nut (repair kit), Stage 1 cross strut to front axle carrier	M14×120×11.9	Nm	100
		Stage 2	Δ°	180

Nm Wheel control, hub

Number	Designation			Model 212 except 4MATIC
BA33.20-P-1008-01O	Nut, upper ball joint to steering knuckle	Stage 1	Nm	70
		Stage 2	Δ°	50

Nm Wheel control, hub

Number	Designation			MODEL 218 except 4MATIC
BA33.20-P-1008-01Q	Nut, upper ball joint to steering knuckle	Stage 1	Nm	70
		Stage 2	Δ°	50

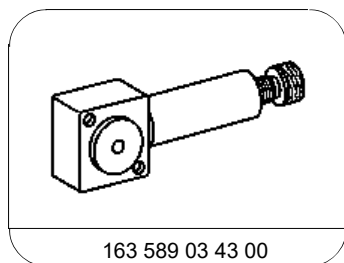

Press

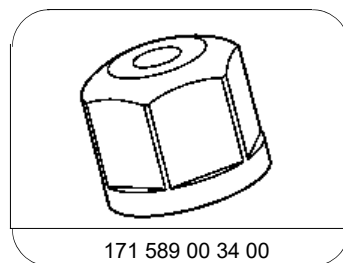

Thrust piece

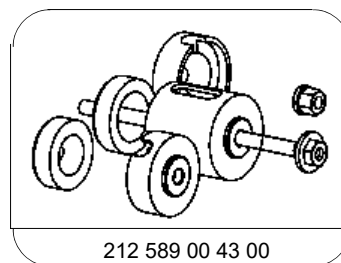

Extraction and installation tool

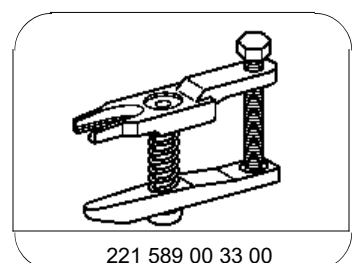

Puller