

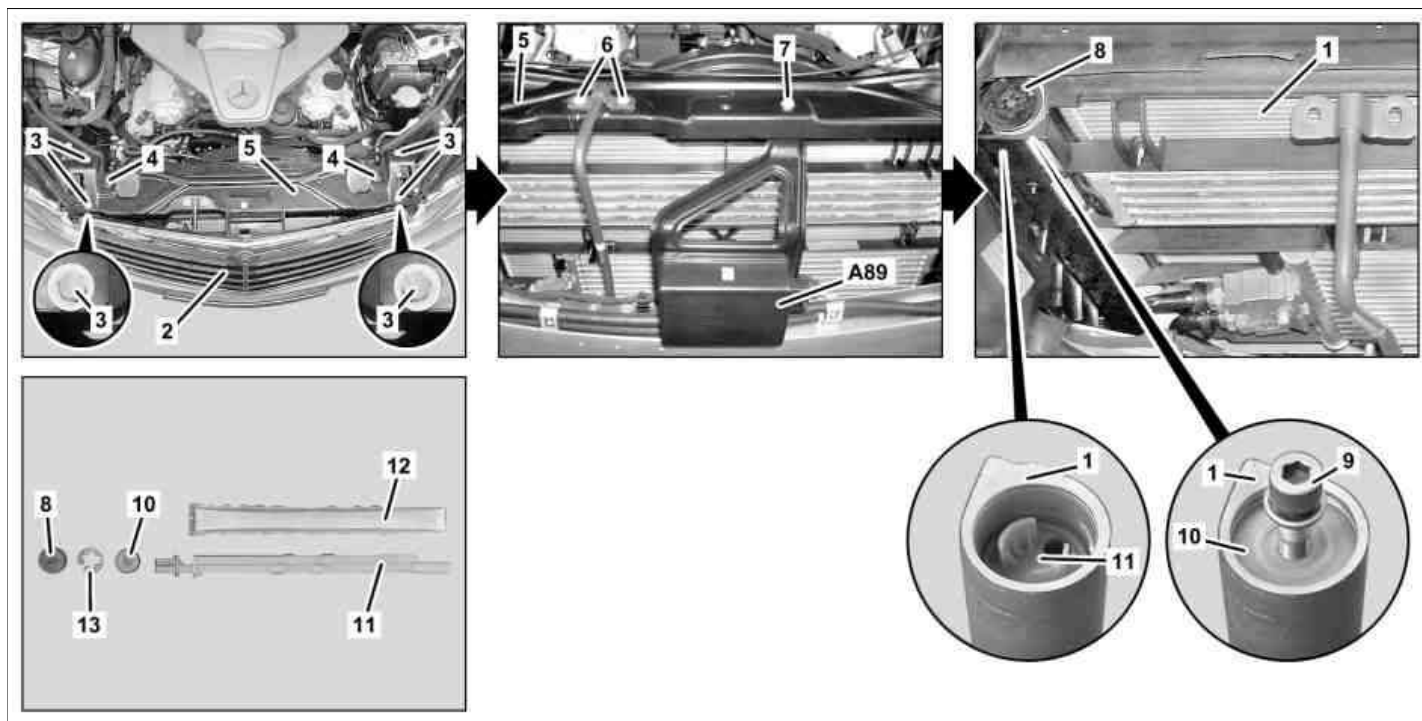





MODEL 212.074/075/076/077/092/274/275/276/277/292



P83.30-4694-09

- | | | | | | |
|---|----------------------|----|------------|-----|------------------------------------|
| 1 | Condenser | 6 | Bolts | 11 | Bracket |
| 2 | Radiator grille | 7 | Screw | 12 | Desiccant bag |
| 3 | Bolts | 8 | Screw plug | 13 | Retaining ring |
| 4 | Clip | 9 | Bolt M8 | A89 | DISTRONIC electric controller unit |
| 5 | Radiator crossmember | 10 | Drier head | | |

	Remove		
1	Drain air conditioning system, then disconnect filler connections		AR83.30-P-1760CW
2	Remove radiator grille (2)	MODEL 212.074/075/076/077/092/274/275/276/277/292 up to model year 2014	AR88.40-P-4001EW
3	Remove front bumper	MODEL 212.074/075/076/077/092/274/275/276/277/292 as of model year 2014	AR88.20-P-2000EWM
4	Unclip clips (4)		
5	Remove screws/bolts (3)		
6	Unscrew bolt (7)	MODEL 212.074/075/076/077/092/274/275/276/277/292 with CODE 233 (DISTRONIC PLUS)	
7	Remove screws/bolts (6) and remove radiator crossmember (5)		
8	Remove screw plug (8) from condenser (1)		
9	Screw screw/bolt M8 (9) into drier head (10)	Screw/bolt M8 (9) is not included in the parts kit of the new desiccant bag (12). Screw/bolt M8 (9) is only required as a disassembly and assembly aid.	

10	Press down drier head (10) to ensure freedom of movement of retaining ring (13)		
11	Remove retaining ring (13)		
12	Remove drier head (10) from condenser (1) by pulling up at screw/bolt M8 (9)		
13	Remove bracket (11) by alternately turning left and right and at the same time pulling up out of condenser (1)		
	Install		
14	Check packaging of new desiccant bag (12) for damage, then unpack desiccant bag (12)	 If packaging is not airtight, dispose of desiccant bag (12). Install the desiccant bag (12) no more than 20 minutes after opening the packaging. Otherwise the desiccant bag (12) is unusable.	
15	Insert new desiccant bag (12) into new holder (11)		
16	Insert bracket (11) with desiccant bag (12) in condenser (1)	 Carefully insert desiccant bag (12) by hand and without using tools. Otherwise the desiccant bag (12) may be damaged. Please avoid jamming the holder (11), otherwise the holder (11) may break. Align desiccant bag (12) with vehicle center.	
17	Screw screw/bolt M8 (9) into new drier head (10) and insert drier head (10) into condenser (1) up to end stop	 Screw/bolt M8 (9) is not included in the parts kit of the new desiccant bag (12). Screw/bolt M8 (9) is only required as a disassembly and assembly aid.	
18	Install retaining ring (13)		
19	Pull drier head (10) up to stop at retaining ring (13)		
20	Remove screw/bolt M8 (9) from drier head (10)		
21	Tighten screw plug (8)	 Do not tighten screw plug (8) too tight. Otherwise the seal of the screw plug (8) will be damaged and the air conditioning will become leaky.	
22	Insert and position radiator crossmember (5)		
23	Tighten screw/bolts (3)		
24	Tighten bolts (6)	 Bolt for attaching striker	*BA62.30-P-1003-02G
25	Tighten screw (7)	MODEL 212.074/075/076/077/092/274/275/276/277/292 with CODE 233 (DISTRONIC PLUS)	
26	Clip in clips (4)		
27	Install front bumper	MODEL 212.074/075/076/077/092/274/275/276/277/292 as of model year 2014	AR88.20-P-2000EWM
28	Install radiator grille (2)	MODEL 212.074/075/076/077/092/274/275/276/277/292 up to model year 2014	AR88.40-P-4001EW
29	Evacuate the air conditioning system, refill it, and then check the system to make sure that it functions correctly and does not leak.		AR83.30-P-1760CW
30	Calibrate DISTRONIC system	MODEL 212.074/075/076/077/092/274/275/276/277/292 with CODE 233 (DISTRONIC PLUS)	AR30.30-P-1010EW

 **Front end with front reinforcement**

Number	Designation	MODEL 212
BA62.30-P-1003-02G	Bolt for attaching striker	Nm 10