

Model 204.08/09/28/29/38/904/937/98/99, 216.38/39, 221.08/18
 Model 212
 with code M005 (4MATIC)
 Model 218
 with code M005 (4MATIC)
 Model 221.09/19
 with code M005 (4MATIC)

Shown on MODEL 212 with CODE M005 (4MATIC)

- 1 Steering knuckle
- 9 Axle-shaft flange
- 9n Angular contact ball bearing (double-row)
- 9p Retaining ring

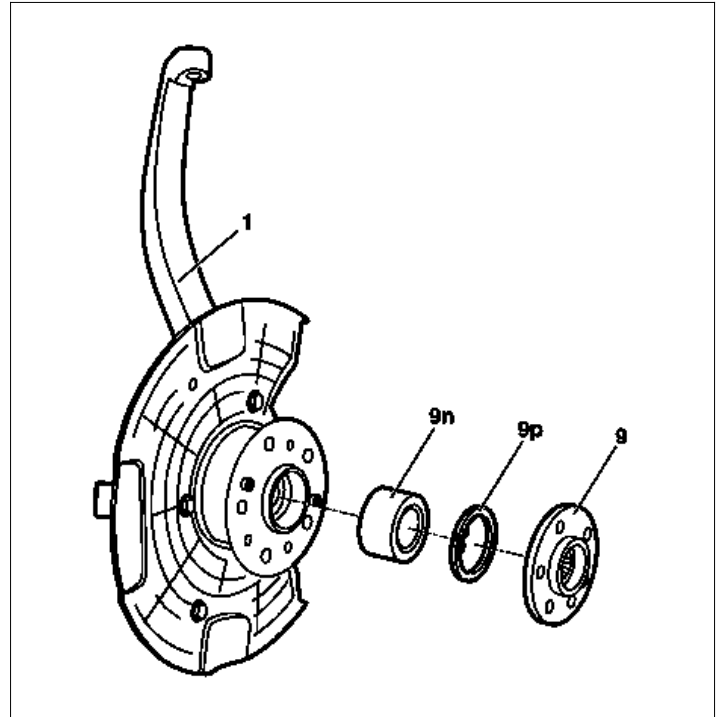

P33.20-2160-12

Shown on MODEL 212 with CODE M005 (4MATIC)

- 1 Steering knuckle
- 2 Bolts
- 3 Shield
- 9 Axle-shaft flange



P33.20-2291-11

	Notes on self-locking nuts and bolts		AH00.00-N-0001-01A
	Notes on repair work on suspension components		AH00.00-P-0100-01A
	Remove		

9	Press axle shaft flange (9) into steering knuckle (1)	<p>Model 204.08# #R as of 020955 Model 204.08#/09#/28#/29#/38#/904/937/98#/99# #F as of 056725 Model 204.08#/09#/38# #A as of 077966 Model 212 with code M005 (4MATIC) Model 216.38/39, 221.08#/18# #A as of 184982 Model 218 with code M005 (4MATIC) Model 221.09#/19# #A as of 184982 with code M005 (4MATIC)</p> <p>i Always replace axle shaft flange (9) and angular contact ball bearing (9n) as a pair.</p> <p><input checked="" type="checkbox"/> Drift <input checked="" type="checkbox"/> Ram <input checked="" type="checkbox"/> Parallel support</p>	<p>AR33.20-P-0315-01SYZ</p> <p>*202589044303 *211589004304 *168589032100</p>
10	Remove bolts (2) again and install shield (3)	<p>Model 204.08/09/28/29/38/904/937/98/99 Model 212 with code M005 (4MATIC) Model 218 with code M005 (4MATIC)</p> <p>Nm Bolt, brake cover plate to steering knuckle or wheel carrier</p>	*BA42.10-P-1003-06H
11	Install steering knuckle (1)	<p>Model 216.38/39 Model 221.08/18 Model 221.09/19 with code M005 (4MATIC) Model 204.08/09/28/29/38/904/937/98/99 with code M005 (4MATIC) Model 212, 218 with code M005 (4MATIC)</p>	<p>AR33.25-P-0400SYZ</p> <p>AR33.25-P-0400CWX</p> <p>AR33.25-P-0400EWX</p>

Nm Brake disks, brake cover plate

Number	Designation		Model 204	Model 212
BA42.10-P-1003-06H	Bolt, brake cover plate to steering knuckle or wheel carrier	M6	Nm 12	12
		M8	Nm 18	18

Nm Brake disks, brake cover plate

Number	Designation		Model 218
BA42.10-P-1003-06H	Bolt, brake cover plate to steering knuckle or wheel carrier	M6	Nm 12
		M8	Nm 18

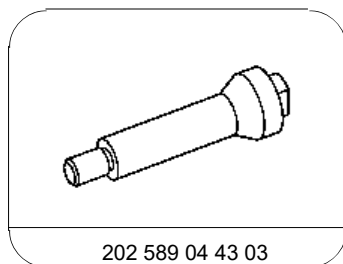

Drift

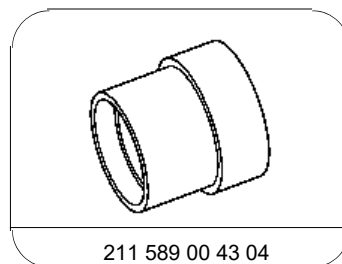

Ram

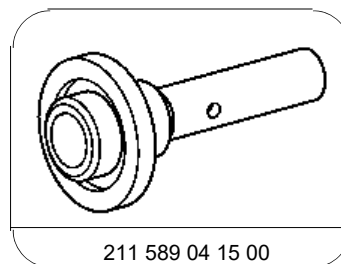

Drift

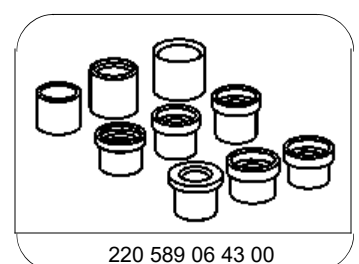

Extraction and insertion tool

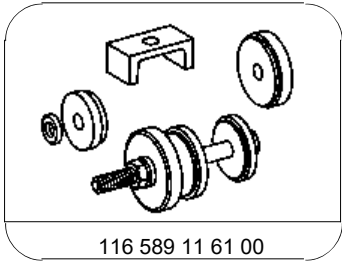

116 589 11 61 00

Installer

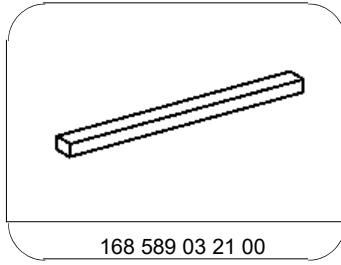

168 589 03 21 00

Parallel support