

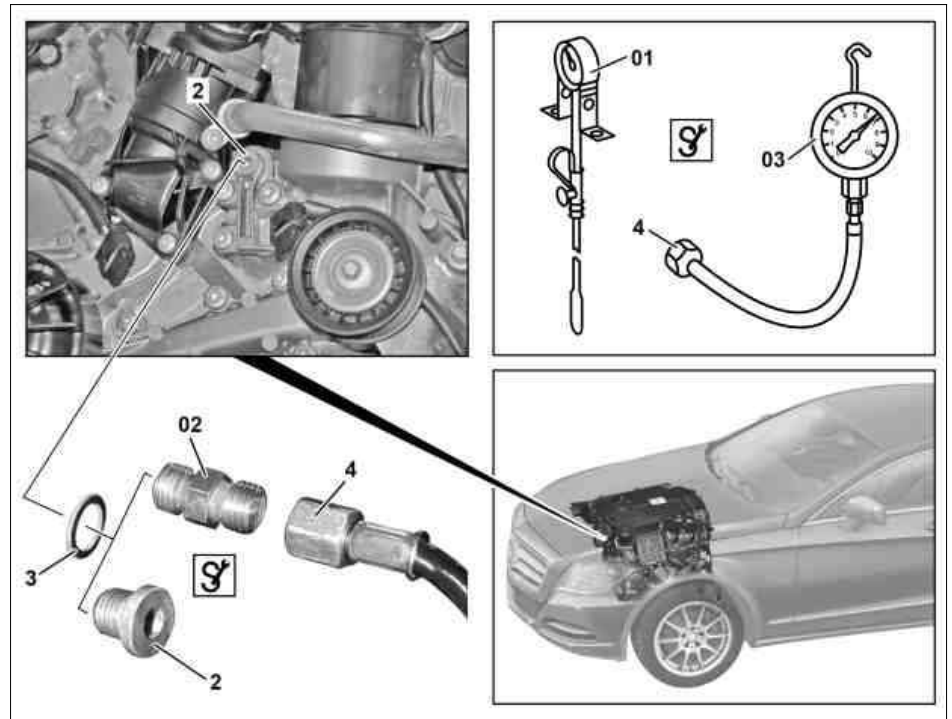











## ENGINE 157, 276, 278 in MODEL 212, 218

## Shown on engine 276.9

- 01 Remote thermometer  
 02 Double union  
 03 Test equipment  
 2 Screw plug  
 3 Sealing ring  
 4 Hose connection



P18.00-2302-06

◀	Check		
	<b>Risk of accident</b> from vehicle starting off by itself when engine running. <b>Risk of injury</b> (bruises and burns) resulting from working on the engine while it is being started or when it is running.	Secure vehicle to prevent it from starting off by itself. Wear closed and snug-fitting work clothes. Do not touch hot or rotating parts.	AS00.00-Z-0005-01A
1	Run engine until warm		
2	Check engine oil temperature with remote thermometer (01)	<p><b>i</b> Lead temperature sensor for the  remote thermometer (01) through oil dipstick guide tube into the engine oil.</p> <p><b>i</b> The engine oil temperature must be at least 100°C.</p> <p> Remote thermometer</p>	*124589072100
3	Check engine oil level approx. 5 min. after switching off the engine at operating temperature and correct if necessary	<p> Vehicle must be horizontal and standing on its wheels. False measurements can occur otherwise.</p>	
 	<b>Remove/install</b>		
4.1	Remove engine cover	ENGINE 276.8 in MODEL 212	
4.2	Remove front engine cover	ENGINE 276.9 in MODEL 212, 218	
5	Unclip vacuum line at upper left on charge air cooler and place to one side	ENGINE 276.8 in MODEL 212	
6	Remove screw plug (2) on oil filter housing or timing case cover	<p><b>i</b> <b>Installation:</b> Replace sealing ring (3).</p> <p> ENGINE 157</p> <p> ENGINE 276</p> <p> Engine 278</p>	<p>*BA18.20-P-1002-01Z</p> <p>*BA18.20-P-1004-01Y</p> <p>*BA18.20-P-1005-01Y</p>
7	Screw double union (02) with sealing ring (3) into the hole in the oil filter housing or timing case cover	<p> ENGINE 157</p> <p> ENGINE 276</p> <p> Engine 278</p>	<p>*BA18.20-P-1002-01Z</p> <p>*BA18.20-P-1004-01Y</p> <p>*BA18.20-P-1005-01Y</p>

		Double connection	*166589006300
8	Mount hose connection (4) of test equipment (03) on double union (02)	Tester	*103589002100
	<b>Measure using pointer device</b>		
9	Start engine and measure oil pressure	Position test equipment (03) in such a way that it is not caught by the poly-V belt when starting the engine. Damage will occur otherwise on the  test equipment (03) and poly-V belt. Measure oil pressure at the engine operating temperature. When the throttle is opened, the oil pressure must rise without any delay. Oil pressure at operating temperature	*BE18.00-P-1001-01B
10	Install in the reverse order		
11	Check engine oil level approx. 5 min. after switching off the engine at operating temperature and correct if necessary	Vehicle must be horizontal and standing on its wheels. False measurements can occur otherwise.	
12	Carry out an engine test run and check engine for leaktightness		

#### Prüfwerte Öldruck

Number	Designation		MOTOR 276	MOTOR 157, 278	
BE18.00-P-1001-01B	Oil pressure at operating temperature	–	bar	0,9...1,1	0,9...1,1
		at	1/min	600	600
		–	bar	1,7...2,3	1,7...2,3
		at	1/min	2500	2500
		–	bar	3,5...5,0	3,5...5,0
		at	1/min	3500	3500

#### Oil filter

Number	Designation			ENGINE 276
BA18.20-P-1004-01Y	Screw plug to oil duct cover	M12	Nm	20

#### Oil filter

Number	Designation			ENGINE 278
BA18.20-P-1005-01Y	Screw plug to oil filter housing	M12	Nm	20

#### Oil filter

Number	Designation			ENGINE 157
BA18.20-P-1002-01Z	Screw plug to oil filter housing	M12	Nm	20

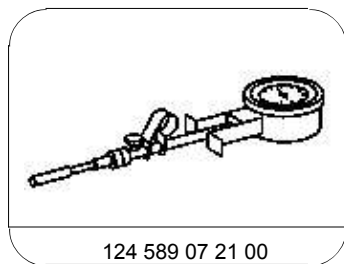

Remote thermometer

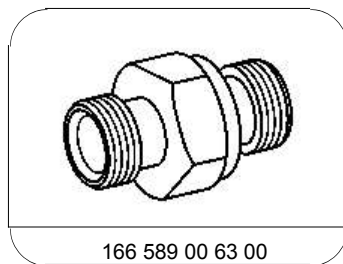

Double connection

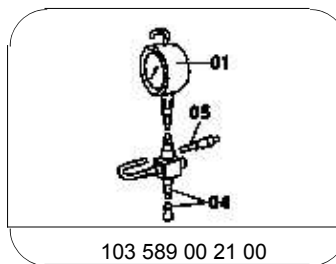

Tester