

TRANSMISSION 722.9 in MODEL 172, 212, 218

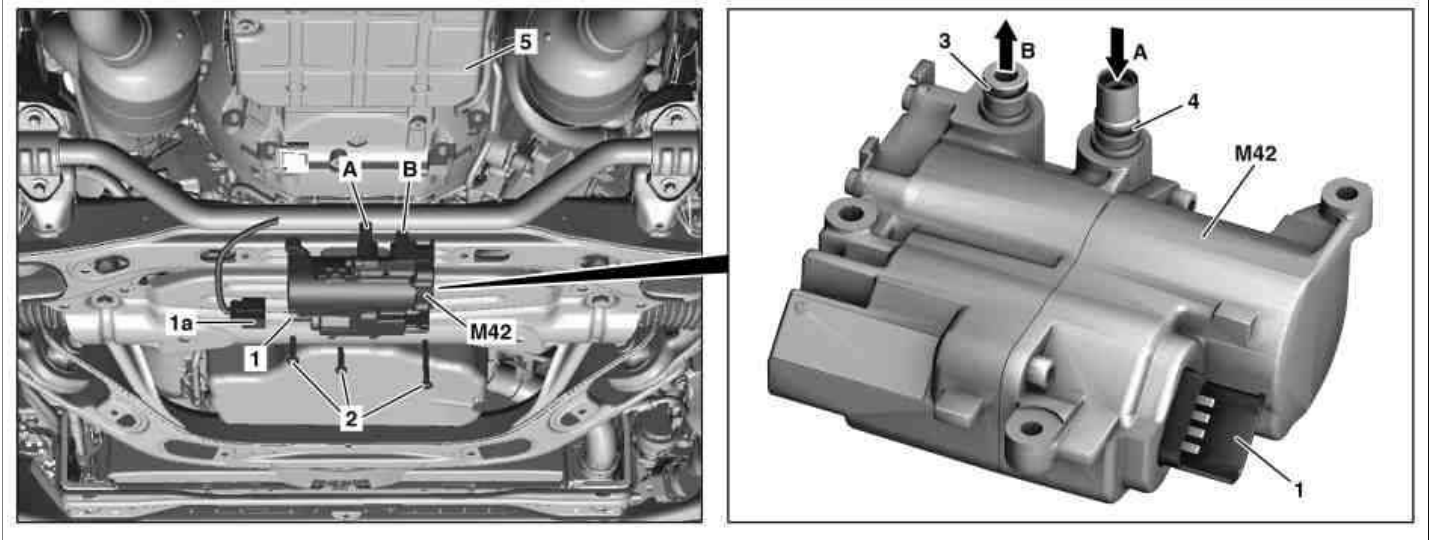

P27.30-2012-08

- 1 Electrical plug connection
- 1a Electrical connector
- 2 Screw

- 3 Oil guide pipe with sealing ring
- 4 Oil guide pipe with sealing ring
- 5 Transmission

- M42 Electric transmission oil pump
- A Intake side
- B Thrust side

☒ ☒	Remove/install		
		<p>ⓘ Before starting the work the area surrounding the connecting points on the transmission (5) must be thoroughly cleaned. Even the smallest dirt particles in the hydraulic components can lead to malfunctions and a total failure of the transmission (5).</p>	
1.1	Remove bottom section of soundproofing	Vehicles with diesel engine Model 172 Model 212, 218	AR94.30-P-5300W AR94.30-P-5300EW
1.2	Remove engine compartment paneling	Vehicles with gasoline engine Model 172 Model 212, 218	AR61.20-P-1105W <b>AR61.20-P-1105EW</b>
2	Remove drain screw from transmission oil pan	<p>ⓘ Collect escaping ATF with drain pan. Note automatic transmission oil quantity.</p> <p>ⓘ It is <b>not</b> necessary to pry off the overflow pipe from the base of the transmission oil pan.</p> <p>Drain pan <a href="https://www.gotit.com/S/18.1_08.0">gotit://S 18.1 08.0</a></p>	
3	Detach electrical connector (1a) on electric transmission oil pump (M42)		
4	Detach electrical wiring harness from transmission (5) and set aside		
5	Remove screws (2) and detach electric transmission oil pump (M42)	<p>When reinstalling the electric transmission oil pump (M42): ↓</p> <p>☒ <b>Installation:</b> Check the oil guide pipe with sealing ring (3, 4) on the intake and pressure side (A, B) and replace if necessary.</p> <p>Nm</p>	*BA27.55-P-1009-01D
6	Install in the reverse order		
7	Fill transmission (5) with oil.	Vehicles without 4MATIC Vehicles with 4MATIC	AR27.00-P-0270W AR27.00-P-0270SYZ
☒	<b>Checking</b>		

8	<p><b>Risk of accident</b> caused by vehicle starting off by itself when engine is running. <b>Risk of injury</b> caused by contusions and burns during starting procedure or when working near the engine as it is running</p> <p>Perform engine test run and check transmission (5) for function and leaks</p>	<p>Secure vehicle to prevent it from moving by itself.</p> <p>Wear closed and snug-fitting work clothes.</p> <p>Do not touch hot or rotating parts.</p>	AS00.00-Z-0005-01A
---	--	---	--------------------

**Nm** Transmission oil cooling system

Number	Designation	Transmission 722.9
BA27.55-P-1009-01D	Bolt, transmission oil auxiliary pump to transmission housing	Nm 8